

GARMIN

CIRRUS PERSPECTIVE®

BY GARMIN.



Cirrus SR2x

**Integrated Avionics System, Cockpit Reference Guide
System Software Version 0764.36 or later**

FLIGHT INSTRUMENTS

EIS

NAV/COM/TRANSPONDER/AUDIO PANEL

AUTOMATIC FLIGHT CONTROL SYSTEM

GPS NAVIGATION

FLIGHT PLANNING

PROCEDURES

HAZARD AVOIDANCE

ADDITIONAL FEATURES

ABNORMAL OPERATION

ANNUNCIATIONS & ALERTS

APPENDIX

INDEX

This manual reflects the operation of System Software 0764.36 or later for the Cirrus Perspective by Garmin Integrated Avionics System. Where used, references to 'SR2x' are inclusive of the SR20, SR22 (3400 lb & 3600 lb GW), SR22TN (3400 lb GW only), and SR22T (3400 lb & 3600 lb GW). Some differences in operation may be observed when comparing the information in this manual to earlier or later software versions. Always refer to the FAA approved pertinent flight manual for a description of systems, limitations, and procedures.

Garmin International, Inc.

1200 East 151st Street
Olathe, Kansas 66062, U.S.A.

Garmin (Europe) Ltd.

Liberty House, Hounsdown Business Park
Southampton, Hampshire SO40 9LR U.K.

Garmin AT, Inc.

2345 Turner Road SE
Salem, OR 97302, U.S.A.

Garmin Corporation

No. 68, Zhangshu 2nd Road
Xizhi District, New Taipei City, Taiwan

Contact Garmin Product Support at www.flygarmin.com.

For warranty information refer to www.flygarmin.com.

Except as expressly provided herein, no part of this manual may be reproduced, copied, transmitted, disseminated, downloaded or stored in any storage medium, for any purpose without the express written permission of Garmin. Garmin hereby grants permission to download a single copy of this manual and of any revision to this manual onto a hard drive or other electronic storage medium to be viewed for personal use, provided that such electronic or printed copy of this manual or revision must contain the complete text of this copyright notice and provided further that any unauthorized commercial distribution of this manual or any revision hereto is strictly prohibited.

Garmin®, G1000®, GDL®, FliteCharts®, ConnexT®, and SafeTaxi® are registered trademarks of Garmin International, Inc. or its subsidiaries. Garmin ESP™, Garmin SVT™, and SurfaceWatch™ are trademarks of Garmin International, Inc. or its subsidiaries. These trademarks may not be used without the express permission of Garmin.

Perspective™ is a trademark of Cirrus Design Corporation.

Skywatch® and Stormscope® are registered trademarks of L-3 Communications. Ryan®, TCAD® and Avidyne® are registered trademarks of Avidyne Corporation. CO Guardian is a trademark of CO Guardian, Inc. AC-U-KWIK® is a registered trademark of Penton Business Media Inc. Bendix/King® and Honeywell® are registered trademarks of Honeywell International, Inc. Becker® is a registered trademark of Becker Flugfunkwerk GmbH. NavData® is a registered trademark of Jeppesen, Inc.; Wi-Fi® is a registered trademark of the Wi-Fi Alliance. Sirius, XM, and all related marks and logos are trademarks of Sirius XM Radio, Inc. and its subsidiaries. The Bluetooth® word mark and logos are owned by the Bluetooth SIG, Inc. and any use of such marks by Garmin is under license.

AOPA Membership Publications, Inc. and its related organizations (hereinafter collectively "AOPA") expressly disclaim all warranties, with respect to the AOPA information included in this data, express or implied, including, but not limited to, the implied warranties of merchantability and fitness for a particular purpose. The information is provided "as is" and AOPA does not warrant or make any representations regarding its accuracy, reliability, or otherwise. Under no circumstances including negligence, shall AOPA be liable for any incidental, special or consequential damages that result from the use or inability to use the software or related documentation, even if AOPA or an AOPA authorized representative has been advised of the possibility of such damages. User agrees not to sue AOPA and, to the maximum extent allowed by law, to release and hold harmless AOPA from any causes of action, claims or losses related to any actual or alleged inaccuracies in the information. Some jurisdictions do not allow the limitation or exclusion of implied warranties or liability for incidental or consequential damages so the above limitations or exclusions may not apply to you.

AC-U-KWIK and its related organizations (hereafter collectively "AC-U-KWIK Organizations") expressly disclaim all warranties with respect to the AC-U-KWIK information included in this data, express or implied, including, but not limited to, the implied warranties of merchantability and fitness for a particular purpose. The information is provided "as is" and AC-U-KWIK Organizations do not warrant or make any representations regarding its accuracy, reliability, or otherwise. Licensee agrees not to sue AC-U-KWIK Organizations and, to the maximum extent allowed by law, to release and hold harmless AC-U-KWIK Organizations from any cause of action, claims or losses related to any actual or alleged inaccuracies in the information arising out of Garmin's use of the information in the datasets. Some jurisdictions do not allow the limitation or exclusion of implied warranties or liability for incidental or consequential damages so the above limitations or exclusions may not apply to licensee.

Printed in the U.S.A.



WARNING: Do not use terrain avoidance displays as the sole source of information for maintaining separation from terrain and obstacles. Garmin obtains terrain and obstacle data from third party sources and cannot independently verify the accuracy of the information.



WARNING: Always refer to current aeronautical charts and NOTAMs for verification of displayed aeronautical information. Displayed aeronautical data may not incorporate the latest NOTAM information.



WARNING: Do not use geometric altitude for compliance with air traffic control altitude requirements. The primary barometric altimeter must be used for compliance with all air traffic control altitude regulations, requirements, instructions, and clearances.



WARNING: Do not use basemap information (land and water data) as the sole means of navigation. Basemap data is intended only to supplement other approved navigation data sources and should be considered only an aid to enhance situational awareness.



WARNING: Do not rely solely upon the display of traffic information to accurately depict all of the traffic within range of the aircraft. Due to lack of equipment, poor signal reception, and/or inaccurate information from aircraft or ground stations, traffic may be present that is not represented on the display.



WARNING: Do not use data link weather information for maneuvering in, near, or around areas of hazardous weather. Information contained within data link weather products may not accurately depict current weather conditions.



WARNING: Do not use the indicated data link weather product age to determine the age of the weather information shown by the data link weather product. Due to time delays inherent in gathering and processing weather data for data link transmission, the weather information shown by the data link weather product may be older than the indicated weather product age.



WARNING: Do not rely on the displayed minimum safe altitude (MSAs) as the sole source of obstacle and terrain avoidance information. Always refer to current aeronautical charts for appropriate minimum clearance altitudes.



WARNING: Do not operate this equipment without first obtaining qualified instruction.



WARNING: Do not use GPS to navigate to any active waypoint identified as a 'NON WGS84 WPT' by a system message. 'NON WGS84 WPT' waypoints are derived from an unknown map reference datum that may be incompatible with the map reference datum used by GPS (known as WGS84) and may be positioned in error as displayed.



WARNING: Do not rely on the autopilot to level the aircraft at the MDA/DH when flying an approach with vertical guidance. The autopilot will not level the aircraft at the MDA/DH even if the MDA/DH is set in the altitude preselect.



WARNING: Do not rely solely upon the display of traffic information for collision avoidance maneuvering. The traffic display does not provide collision avoidance resolution advisories and does not under any circumstances or conditions relieve the pilot's responsibility to see and avoid other aircraft.



WARNING: Do not rely on the accuracy of attitude and heading indications in the following geographic areas (due to variations in the earth's magnetic field): North of 72° North latitude at all longitudes; South of 70° South latitude at all longitudes; North of 65° North latitude between longitude 75° W and 120° W. (Northern Canada); North of 70° North latitude between longitude 70° W and 128° W. (Northern Canada); North of 70° North latitude between longitude 85° E and 114° E. (Northern Russia); South of 55° South latitude between longitude 120° E and 165° E. (Region south of Australia and New Zealand).



WARNING: Do not rely on information from a lightning detection system display as the sole basis for hazardous weather avoidance. Range limitations and interference may cause the system to display inaccurate or incomplete information. Refer to documentation from the lightning detection system manufacturer for detailed information about the system.



WARNING: Use appropriate primary systems for navigation, and for terrain, obstacle, and traffic avoidance. Garmin SVT is intended as an aid to situational awareness only and may not provide either the accuracy or reliability upon which to solely base decisions and/or plan maneuvers to avoid terrain, obstacles, or traffic.



WARNING: Do not use TAWS information for primary terrain or obstacle avoidance. TAWS is intended only to enhance situational awareness.



WARNING: Do not use a QFE altimeter setting with this system. System functions will not operate properly with a QFE altimeter setting. Use only a QNH altimeter setting for height above mean sea level, or the standard pressure setting, as applicable.



CAUTION: Do not clean display surfaces with abrasive cloths or cleaners containing ammonia. They will harm the anti-reflective coating.



CAUTION: Do not allow repairs to be made by anyone other than an authorized Garmin service center. Unauthorized repairs or modifications could void both the warranty and affect the airworthiness of the aircraft.



NOTE: Do not rely solely upon data link services to provide Temporary Flight Restriction (TFR) information. Always confirm TFR information through official sources such as Flight Service Stations or Air Traffic Control.



NOTE All visual depictions contained within this document, including screen images of the system panel and displays, are subject to change and may not reflect the most current system and aviation databases. Depictions of equipment may differ slightly from the actual equipment.



NOTE: The United States government operates the Global Positioning System and is solely responsible for its accuracy and maintenance. The GPS system is subject to changes which could affect the accuracy and performance of all GPS equipment. Portions of the system utilize GPS as a precision electronic NAVigation AID (NAVAID). Therefore, as with all NAVAIDs, information presented by the system can be misused or misinterpreted and, therefore, become unsafe.



NOTE: This device complies with part 15 of the FCC Rules. Operation is subject to the following two conditions: (1) this device may not cause harmful interference, and (2) this device must accept any interference received, including interference that may cause undesired operation.



NOTE: Interference from GPS repeaters operating inside nearby hangars can cause an intermittent loss of attitude and heading displays while the aircraft is on the ground. Moving the aircraft more than 100 yards away from the source of the interference should alleviate the condition.



NOTE: Use of polarized eyewear may cause the flight displays to appear dim or blank.



NOTE: This product, its packaging, and its components contain chemicals known to the State of California to cause cancer, birth defects, or reproductive harm. This notice is being provided in accordance with California's Proposition 65. If you have any questions or would like additional information, please refer to our web site at www.garmin.com/prop65.



NOTE: Operating the system in the vicinity of metal buildings, metal structures, or electromagnetic fields can cause sensor differences that may result in nuisance miscompare annunciations during start up, shut down, or while taxiing. If one or more of the sensed values are unavailable, the annunciation indicates no comparison is possible.



NOTE: The system responds to a terminal procedure based on data coded within that procedure in the Navigation Database. Differences in system operation may be observed among similar types of procedures due to differences in the Navigation Database coding specific to each procedure.



NOTE: The FAA has asked Garmin to remind pilots who fly with Garmin database-dependent avionics of the following:

- It is the pilot's responsibility to remain familiar with all FAA regulatory and advisory guidance and information related to the use of databases in the National Airspace System.
- Garmin equipment will only recognize and use databases that are obtained from Garmin or Jeppesen. Databases obtained from Garmin or Jeppesen are assured compliance with all data quality requirements (DQRs) by virtue of a Type 2 Letter of Authorization (LOA) from the FAA. A copy of the Type 2 LOA is available for each database and can be viewed at <http://fly.garmin.com> by selecting 'Type 2 LOA Status.'
- Use of a current Garmin or Jeppesen database in your Garmin equipment is required for compliance with established FAA regulatory guidance, but does not constitute authorization to fly any and all terminal procedures that may be presented by the system. It is the pilot's responsibility to operate in accordance with established AFM(S) and regulatory guidance or limitations as applicable to the pilot, the aircraft, and installed equipment.



NOTE: The pilot/operator must review and be familiar with Garmin's database exclusion list as discussed in SAIB CE-14-04 to determine what data may be incomplete. The database exclusion list can be viewed at www.flygarmin.com by selecting 'Database Exclusions List.'



NOTE: The pilot/operator must have access to Garmin and Jeppesen database alerts and consider their impact on the intended aircraft operation. The database alerts can be viewed at www.flygarmin.com by selecting 'Aviation Database Alerts.'



NOTE: If the pilot/operator wants or needs to adjust the database, contact Garmin Product Support.



NOTE: Garmin requests the flight crew report any observed discrepancies related to database information. These discrepancies could come in the form of an incorrect procedure; incorrectly identified terrain, obstacles and fixes; or any other displayed item used for navigation or communication in the air or on the ground. Go to FlyGarmin.com and select 'Aviation Data Error Report'.



NOTE: *Electronic aeronautical charts displayed on this system have been shown to meet the guidance in AC 120-76D as a Type B Electronic Flight Bag (EFB) for FliteCharts and ChartView. The accuracy of the charts is subject to the chart data provider. Own-ship position on airport surface charts cannot be guaranteed to meet the accuracy specified in AC 120-76D. Possible additional requirements may make a secondary source of aeronautical charts, such as traditional paper charts or an additional electronic display, necessary on the aircraft and available to the pilot. If the secondary source of aeronautical charts is a Portable Electronic Device (PED), its use must be consistent with the guidance in AC 120-76D.*



NOTE: *The navigation databases used in Garmin navigation systems contain Special Procedures. Prior to flying these procedures, pilots must have specific FAA authorization, training, and possession of the corresponding current, and legitimately-sourced chart (approach plate, etc.). Inclusion of the Special Procedure in the navigation database DOES NOT imply specific FAA authorization to fly the procedure.*



NOTE: *Terrain and obstacle alerting is not available north of 89° North latitude and south of 89° South latitude. This is due to limitations present within the Terrain database and the system's ability to process the data representing the affected areas.*



NOTE: *Lamp(s) inside this product contain mercury (HG) and must be recycled or disposed of according to local, state, or federal laws. For more information, refer to our website at www.garmin.com/en-US/company/environment/recycling*



NOTE: *When using Stormscope, there are several atmospheric phenomena in addition to nearby thunderstorms that can cause isolated discharge points in the strike display mode. However, clusters of two or more discharge points in the strike display mode do indicate thunderstorm activity if these points reappear after the screen has been cleared.*



NOTE: *Intruder aircraft at or below 500 ft. AGL may not appear on the Garmin SVT display or may appear as a partial symbol.*



NOTE: *The nose of the 'own ship' symbol represents the location of the aircraft. The center of any traffic symbol represents the location of that traffic. The traffic and own ship symbols are an abstract representation and do not reflect the physical extent of the aircraft/traffic, and should not replace other methods for identifying traffic.*



NOTE: *Operate Perspective™ system power through at least one cycle in a period of four days of continuous operation to avoid an autonomous system reboot.*



NOTE: *The purpose of this Cockpit Reference Guide is to provide the pilot a resource with which to find operating instructions on the major features of the Perspective system more easily. It is not intended to be a comprehensive operating guide. Complete operating procedures for the system are found in the Perspective Pilot's Guide for this aircraft.*

Blank Page

SOFTWARE LICENSE AGREEMENT

BY USING THE DEVICE, COMPONENT OR SYSTEM MANUFACTURED OR SOLD BY GARMIN ("THE GARMIN PRODUCT"), YOU AGREE TO BE BOUND BY THE TERMS AND CONDITIONS OF THE FOLLOWING SOFTWARE LICENSE AGREEMENT. PLEASE READ THIS AGREEMENT CAREFULLY. Garmin Ltd. and its subsidiaries ("Garmin") grants you a limited license to use the software embedded in the Garmin Product (the "Software") in binary executable form in the normal operation of the Garmin Product. Title, ownership rights, and intellectual property rights in and to the Software remain with Garmin and/or its third-party providers. You acknowledge that the Software is the property of Garmin and/or its third-party providers and is protected under the United States of America copyright laws and international copyright treaties. You further acknowledge that the structure, organization, and code of the Software are valuable trade secrets of Garmin and/or its third-party providers and that the Software in source code form remains a valuable trade secret of Garmin and/or its third-party providers. You agree not to reproduce, decompile, disassemble, modify, reverse assemble, reverse engineer, or reduce to human readable form the Software or any part thereof or create any derivative works based on the Software. You agree not to export or re-export the Software to any country in violation of the export control laws of the United States of America.

Blank Page

Part Number	Change Summary
190-00821-00 Rev A	Initial release
Rev B	Made clerical changes
Rev C	Made clerical changes to pages 8 and 91
190-00821-01	<ul style="list-style-type: none"> Added Enhanced Vision System Added changes in page navigation Added new procedures for creating user waypoints Added importing and exporting flight plans Updated Warning Alerts, Caution Alerts, and Advisory Annunciations Added new XM Weather product symbols Added other GDU 9.10 parameters
190-00821-02	<ul style="list-style-type: none"> Added SR20 engine display operation Added FIKI Anti-icing system GDU 9.12
190-00821-03	<ul style="list-style-type: none"> Added AOPA Airport Directory Added dual navigation database capability Added database synchronization Added GDU 10.00 parameters
190-00821-04	<ul style="list-style-type: none"> Added the SR22 Turbo Added GDU 11.00 parameters
190-00821-05	<ul style="list-style-type: none"> Added GTS 800 Traffic Advisory System Changed SR22 Turbo to SR22T
190-00821-06	<ul style="list-style-type: none"> Added Profile View Updated Active Flight Plan modification procedures to include the Quick Select Box and Insertion Point Indicator Updated XM Weather product status display Added Electronic Stability & Protection Added Underspeed Protection Added Hypoxia Detection System Added other GDU 11.11 parameters

Part Number	Change Summary
190-00821-07	Added GMA 350 Audio Panel Added Iridium Satellite Telephone Added GFDS Worldwide Weather Added WX LGND, LEGEND, and METAR softkeys Updated system messages Added other GDU 12.01 parameters Added L-3 SKYWATCH [®] Traffic
190-00821-08	Added GDU 12.10 parameters Updated system messages Added Pilot Profiles Import/Export Added Pilot Profile Import/Export messages Updated XM volume and mute procedures Replaced BRG field with ETE on the PFD
190-00821-09	GDU 12.11 Added GDL 59 Added Fuel Quantity Indicators to EIS Updated system messages
190-00821-10	GDU 14.01 Updated Warnings, Cautions, and Notes section Changed references to SVS (Synthetic Vision System) to SVT (Synthetic Vision Technology) Removed references to GFC 700 and replaced with Garmin AFCS Changed references to GFDS and World Wide Weather to Garmin Connex [™] and Connex Weather Removed System Data Logging feature Added Position Reporting feature Added Scheduler feature Added Present Position indication in the Timer/Reference Window Added display of Flight Path Marker independent of SVT Added Temperature Compensated Altitude feature Added User Defined Holding Patterns

Part Number	Change Summary
190-00821-11 Rev. A	Added GDU 15.01 Updated Warnings, Cautions, and Notes section Added Bluetooth® Connection with Audio Panel Added GMA 350c Added GLD 88 Added support for SR18 Updated system messages Updated CAS messages Added Bluetooth® Connection with Flight Stream 210 Added support for GDL 69 SXM/69A SXM Added FIS-B Weather
Rev. B	Made clerical changes
190-00821-12 Rev. A	Updated AoA information Removed support for SR18 Added Visual Reporting Points Updated CAS Annunciations Updated Aural Alerts Clerical Changes throughout

Revision	Date of Revision	Affected Pages	Description
A	November, 2018	All	Production Release at GDU 15.24

Blank Page

FLIGHT INSTRUMENTS	1
Selecting the Altimeter Barometric Pressure Setting	1
Selecting Standard Barometric Pressure	1
Change Altimeter Barometric Pressure Setting Units	1
Change Navigation Sources	1
Enable/Disable OBS Mode While Navigating with GPS	1
Generic Timer	2
Present Position Lat/Lon	2
Configure V-speed Bugs	2
Set Barometric Minimum Descent Altitude	3
Displaying Wind Data	3
Selecting The AOA Indicator Display Mode	3
Setting The Baro Transition Alert	4
Setting The Minimum Altitude Alert And Bug	4
ENGINE INDICATION SYSTEM	5
Engine Page	7
NAV/COM/TRANSPONDER/AUDIO PANEL	15
DME Tuning	15
Enter a Transponder Code	15
Selecting a COM Radio	15
Selecting a NAV Radio	16
NAV/COM Tuning	16
Split COM	16
Intercom System (ICS) Isolation	17
Telephone/Entertainment Audio	22
3D Audio (GMA 350/350c only)	24
Bluetooth® (GMA 350c Only)	24
Digital Clearance Player	24
AUTOMATIC FLIGHT CONTROL SYSTEM	25
Garmin AFCS	25
S-TEC Fifty Five X Autopilot (Optional)	28
GPS NAVIGATION	29
Direct-to Navigation	29
Activate a Stored Flight Plan	30
Activate a Flight Plan Leg	30
Stop Navigating a Flight Plan	31
Vertical Navigation (VNAV)	31
FLIGHT PLANNING	35
Trip Planning	35

Create a User Waypoint Defined by Latitude & Longitude	37
Create a User Waypoint Defined by Radials from Other Waypoints	37
Create a User Waypoint Defined by a Radial & Distance from Another Waypoint..	39
Create a User Waypoint Using the Map Pointer	41
Delete a User Waypoint	41
Selecting a VRP	42
Create a Flight Plan	42
Import a Flight Plan from an SD Card	43
Insert a Waypoint in the Active Flight Plan	44
Enter an Airway in a Flight Plan	45
Creating a User-Defined Hold at an Active Flight Plan Waypoint	47
Editing A User-Defined Hold	47
Creating a User-Defined Hold at the Aircraft Present Position	48
Removing a User-Defined Hold (Created at the Aircraft P.POS)	48
Removing a User-Defined Hold (Created at an Active Waypoint)	48
Invert An Active Flight Plan	49
Remove a Departure, Arrival, Approach, or Airway from a Flight Plan	49
Store a Flight Plan	50
Edit a Stored Flight Plan	50
Delete a Waypoint from the Flight Plan	50
Invert and Activate a Stored Flight Plan	51
Copy a Flight Plan	51
Delete a Flight Plan	52
Graphical Flight Plan Creation (Active Flight Plan Only)	52
Export a Flight Plan to an SD Card	52
PROCEDURES	55
Load and Activate a Departure Procedure	55
Activate A Departure Leg	55
Load An Arrival Procedure	56
Activate An Arrival Leg	56
Load and/or Activate an Approach Procedure	57
Activate An Approach in the Active Flight Plan	58
Activate A Vector to Final Approach Fix	58
Activate A Missed Approach in the Active Flight Plan	58
Approach Downgrades	59
Temperature Compensated Altitude	60
HAZARD AVOIDANCE	61
Customizing the Hazard Displays on the Navigation Map	61
Stormscope® (Optional)	61
SiriusXM Weather (Optional)	63
Connex™ Weather (Optional)	65
FIS-B Weather	78

Traffic Advisory Systems	84
Terrain And Obstacle Proximity	91
Terrain-SVT (Optional)	92
Terrain Awareness & Warning System (TAWS-B) Display (Optional)	94
ADDITIONAL FEATURES	97
Synthetic Vision (Optional)	97
Enhanced Vision System (Optional)	98
Terminal Procedure Charts	99
Airport Directory	101
SiriusXM Radio Entertainment (Optional)	101
Satellite Telephone & SMS Messaging Service (Optional)	103
Wi-Fi Connections (Optional)	116
Scheduler	118
Electronic Checklists (Optional)	119
Hypoxia Recognition with Automatic Descent Mode	121
Electronic Stability and Protection (ESP™) (Optional)	122
Pilot Profiles	124
Position Reporting	126
Bluetooth® Management	128
ABNORMAL OPERATION	131
Reversionary Mode	131
Abnormal COM Operation	132
Hazard Displays with Loss of GPS Position	133
Unusual Attitudes	133
Dead Reckoning	134
ANNUNCIATIONS & ALERTS	137
Perspective System Annunciations	137
WARNING Alerts	139
CAUTION Alerts	141
Advisory Annunciations	143
Comparator Annunciations	144
Reversionary Sensor Annunciations	144
Message Advisory Alerts	145
Garmin AFCS Alerts	145
Garmin AFCS Speed Condition/Stall Alert	146
Terrain-SVT Alerts	147
Terrain-SVT System Status Annunciations	148
TAWS-B Alerts	149
TAWS-B System Status Annunciations	150
Voice Alerts	151

CO Guardian Messages	152
System Message Advisories	152
Flight Plan Import/Export Messages	169
Pilot Profile Import/Export Messages	170
ADS-B Status Page Messages	171
APPENDIX	173
PFD Softkey Map	173
MFD Softkey Map	181
Loading Updated Databases	185
INDEX	Index-1

FLIGHT INSTRUMENTS

SELECTING THE ALTIMETER BAROMETRIC PRESSURE SETTING

Turn the **BARO** Knob to select the desired setting.

SELECTING STANDARD BAROMETRIC PRESSURE

Press the **BARO** Knob.

CHANGE ALTIMETER BAROMETRIC PRESSURE SETTING UNITS

- 1) Press the **PFD** Softkey to display the second-level softkeys.
- 2) Press the **ALT UNIT** Softkey.
- 3) Press the **IN** Softkey to display the barometric pressure setting in inches of mercury (in Hg).

Or:

Press the **HPA** Softkey to display the barometric pressure setting in hectopascals.

- 4) Press the **BACK** Softkey to return to the top-level softkeys.

CHANGE NAVIGATION SOURCES

- 1) Press the **CDI** Softkey to change from GPS to VOR1 or LOC1. This places the light blue tuning box over the NAV1 standby frequency in the upper left corner of the PFD.
- 2) Press the **CDI** Softkey again to change from VOR1 or LOC1 to VOR2 or LOC2. This places the light blue tuning box over the NAV2 standby frequency.
- 3) Press the **CDI** Softkey a third time to return to GPS.

ENABLE/DISABLE OBS MODE WHILE NAVIGATING WITH GPS

- 1) Press the **OBS** Softkey to select OBS Mode.
- 2) Turn a **CRS** Knob to select the desired course to/from the waypoint. Press the **CRS** Knob to synchronize the Selected Course with the bearing to the next waypoint.
- 3) Press the **OBS** Softkey again to disable OBS Mode.

GENERIC TIMER

- 1) Press the **TMR/REF** Softkey, then turn the large **FMS** Knob to select the time field (hh/mm/ss). Turn the **FMS** Knobs to set the desired time, then press the **ENT** Key. The UP/DOWN field is now highlighted.
- 2) Turn the small **FMS** Knob to display the UP/DOWN window. Turn the **FMS** Knob to select 'UP' or 'DOWN', then press the **ENT** Key. 'START?' is now highlighted.
- 3) Press the **ENT** Key to START, STOP, or RESET the timer (if the timer is counting DOWN, it will start counting UP after reaching zero). Press the **CLR** Key or the **TMR/REF** Softkey to remove the window.

PRESENT POSITION LAT/LON

- 1) Press the **TMR/REF** Softkey.
- 2) Turn the large **FMS** Knob to scroll to the bottom of the window. The latitude and longitude representing the current aircraft position is displayed in degrees and minutes.

CONFIGURE V-SPEED BUGS



NOTE: V-speed values cannot be adjusted in all models.

- 1) Press the **TMR/REF** Softkey.
- 2) Turn the large **FMS** Knob to highlight the desired V-speed.
- 3) Use the small **FMS** Knob to change the V-speed in 1-kt increments. V_x may be adjusted up to 89 knots and V_y may be adjusted down to 89 knots. V_{glide} and V_{rotate} cannot be adjusted. When a speed has been changed from a default value, an asterisk appears next to the value.
- 4) Press the **ENT** Key or turn the large **FMS** Knob to highlight the ON/OFF field
- 5) Turn the small **FMS** Knob clockwise to ON or counterclockwise to OFF.
- 6) To remove the window, press the **CLR** Key or the **TMR/REF** Softkey.

SET BAROMETRIC MINIMUM DESCENT ALTITUDE

- 1) Press the **TMR/REF** Softkey.
- 2) Turn the large **FMS** Knob to highlight the OFF/BARO field to the right of 'MINIMUMS'.
- 3) Turn the small **FMS** Knob clockwise to BARO.
- 4) Press the **ENT** Key.
- 5) Use the small **FMS** Knob to enter the desired altitude.
- 6) Press the **ENT** Key.
- 7) To remove the window, press the **CLR** Key or the **TMR/REF** Softkey.

DISPLAYING WIND DATA

- 1) Press the **PFD** Softkey.
- 2) For airframes without AOA option, press the **WIND** Softkey then proceed to the next step.

Or:

For airframes with AOA option, press the **AOA/WIND** Softkey then the **WIND** Softkey.

- 3) Press one of the **OPTN** softkeys to change how wind data is displayed:
 - **OPTN 1:** Total wind direction arrow with digital true numeric direction and speed.
 - **OPTN 2:** Headwind/tailwind and crosswind arrows with numeric speed components.
- 4) To remove the window, press the **OFF** Softkey.

SELECTING THE AOA INDICATOR DISPLAY MODE

- 1) Press the **PFD** Softkey.
- 2) Press the **AOA/WIND** Softkey, then the **AOA** Softkey.
- 3) Press the **AOA ON** or **AOA AUTO** Softkey (pressing **AOA ON** again will turn the indicator off).

SETTING THE BARO TRANSITION ALERT

- 1) Use the **FMS** Knob to select the 'AUX - System Setup' Page.
- 2) Push the **FMS** Knob to activate the cursor.
- 3) Turn the large **FMS** Knob to highlight ON or OFF in the Baro Transition Alert box.
- 4) Turn the small **FMS** Knob to turn the alert OFF or ON and press the **ENT** Key.
- 5) With the altitude field highlighted, turn the small **FMS** Knob to set desired altitude and press the **ENT** Key.
- 6) To cancel the selection, push the **FMS** Knob.

SETTING THE MINIMUM ALTITUDE ALERT AND BUG

- 1) Press the **TMR/REF** Softkey.
- 2) Turn the large **FMS** Knob to highlight the Minimums field.
- 3) Turn the small **FMS** Knob to select the desired altitude source: barometric (BARO) or temperature compensated (TEMP COMP). OFF is selected by default. Press the **ENT** Key or turn the large **FMS** Knob to highlight the next field.
- 4) Use the small **FMS** Knob to enter the desired altitude (from zero to 16,000 feet).
- 5) To remove the window, press the **CLR** Key or press the **TMR/REF** Softkey.

ENGINE INDICATION SYSTEM

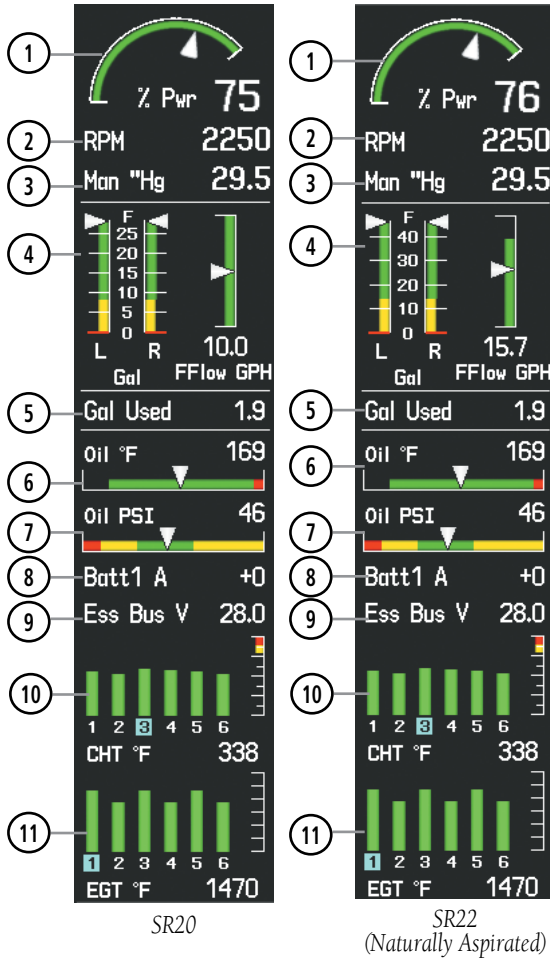

- | | | |
|--|--|---|
| <p>① Percent Power</p> <p>② Tachometer</p> <p>③ Manifold Pressure</p> <p>④ Fuel Quantity & Fuel Flow</p> | <p>⑤ Gallons Used</p> <p>⑥ Oil Temperature</p> <p>⑦ Oil Pressure</p> <p>⑧ Ammeter</p> <p>⑨ Voltmeter</p> | <p>⑩ Cylinder Head Temperature</p> <p>⑪ Exhaust Gas Temperature</p> |
|--|--|---|

- Flight Instruments
- EIS
- Nav/Com/XPDR/Audio
- AFCS
- GPS Nav
- Flight Planning
- Procedures
- Hazard Avoidance
- Additional Features
- Abnormal Operation
- Annun/Alerts
- Appendix
- Index

- Flight Instruments
- EIS
- Nav/Com/XPDR/Audio
- AFCs
- GPS Nav
- Flight Planning
- Procedures
- Hazard Avoidance
- Additional Features
- Abnormal Operation
- Annun/Alerts
- Appendix
- Index

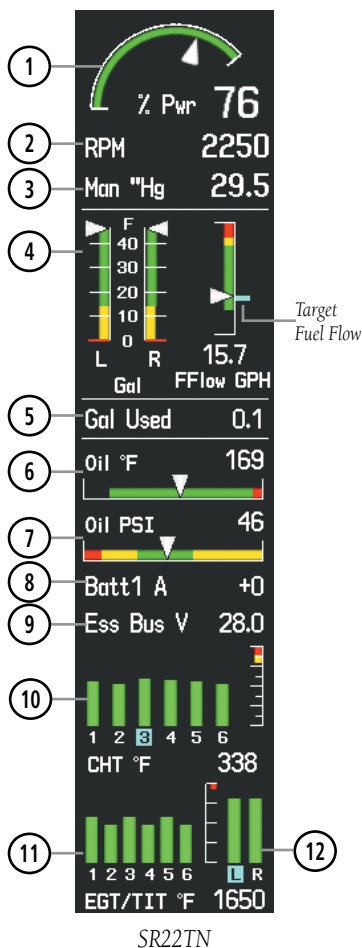
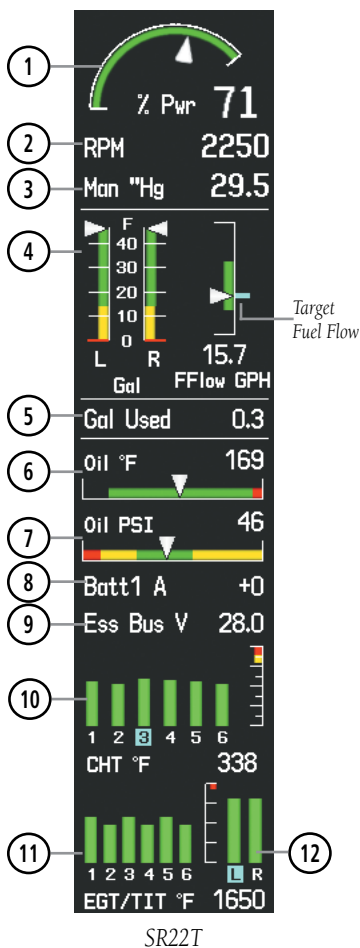

- | | | |
|-----------------------------|-------------------|--|
| ① Percent Power | ⑤ Gallons Used | ⑩ Cylinder Head Temperature |
| ② Tachometer | ⑥ Oil Temperature | ⑪ Exhaust Gas Temperature |
| ③ Manifold Pressure | ⑦ Oil Pressure | ⑫ Left and Right Turbine Inlet Temperature |
| ④ Fuel Quantity & Fuel Flow | ⑧ Ammeter | |
| | ⑨ Voltmeter | |

ENGINE PAGE

Pressing the **ENGINE** Softkey accesses the EIS - Engine Page, which displays all engine, fuel, fuel calculation, electrical, and air data information. Pressing the **FUEL** Softkey accesses the second-level softkeys.



SR20



SR22

- Flight Instruments
- EIS
- Nav/Com/XPDR/Audio
- AFCS
- GPS Nav
- Flight Planning
- Procedures
- Hazard Avoidance
- Additional Features
- Abnormal Operation
- Annun/Alerts
- Appendix
- Index

- Flight Instruments
- EIS
- Nav/Com/XPDR/Audio
- AFCs
- GPS Nav
- Flight Planning
- Procedures
- Hazard Avoidance
- Additional Features
- Abnormal Operation
- Annun/Alerts
- Appendix
- Index



SR22T



SR22TN

- ① Percent Power
- ⑦ Fuel Calculation Group
- ② Tachometer
- ⑧ Fuel Quantity Indicator
- ③ Engine Manifold Pressure
- ⑨ Air Data
- ④ Fuel Flow
- ⑩ Oxygen Pressure
- ⑤ Oil Temperature
- ⑪ Anti-Ice Fluid Quantity Indicator (TKS NH and TKS FIKI)
- ⑥ Electrical Group
- ⑫ Engine Temperature Group

Fuel Calculations



NOTE: Fuel calculations do not use the aircraft fuel quantity indicators and are calculated from the last time the fuel was reset.

Adjusting the fuel totalizer quantity:

- 1) Press the **ENGINE** Softkey to display the Engine Page.
- 2) Press the **FUEL** Softkey to access the Initial Usable Fuel Page.
- 3) Turn the **FMS** Knob (small knob adjusts in 1 gallon increments and large knob in 10 gallon increments) to increase or decrease the initial usable fuel displayed.

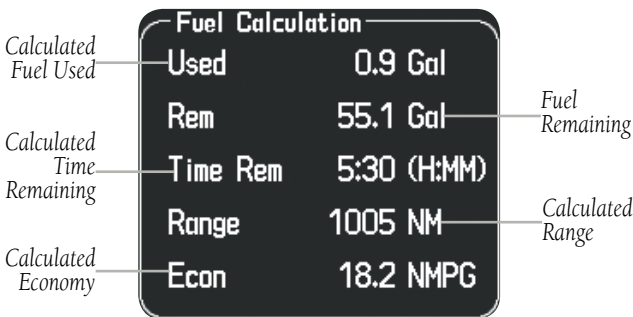

Fuel Calculations Group

- Flight Instruments
- EIS
- Nav/Com/XPDR/Audio
- AFCS
- GPS Nav
- Flight Planning
- Procedures
- Hazard Avoidance
- Additional Features
- Abnormal Operation
- Annun/Alerts
- Appendix
- Index

- Flight Instruments
- EIS**
- Nav/Com/XPDR/Audio
- AFCs
- GPS Nav
- Flight Planning
- Procedures
- Hazard Avoidance
- Additional Features
- Abnormal Operation
- Annun/Alerts
- Appendix
- Index



Full Fuel (SR20)
Initial Usable Fuel Page



Fuel to TABS (SR22)
Initial Usable Fuel Page

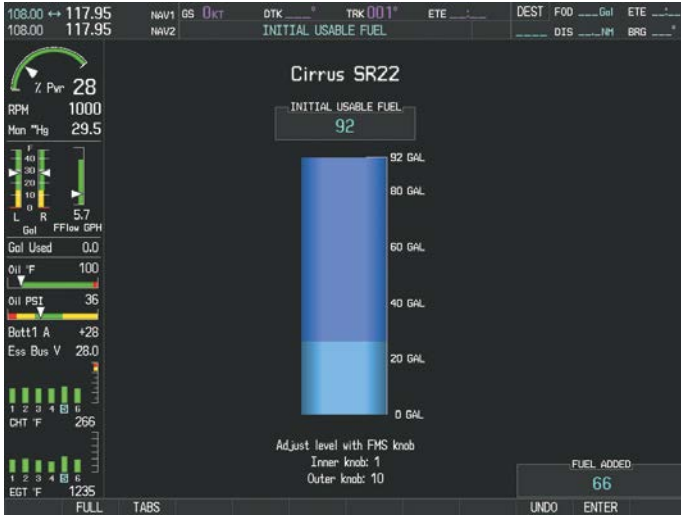

Full Fuel (SR22)
Initial Usable Fuel Page

Leaning Assist Mode



NOTE: The pilot should follow the engine manufacturer’s recommended leaning procedures in the Pilot’s Operating Handbook (POH).

Accessing Leaning Assist Mode:

- 1) Press the **ENGINE** Softkey to display the Engine Page.
- 2) Press the **ASSIST** Softkey to identify peaks.

When the **ASSIST** Softkey is pressed, the system initially highlights the number and places a light blue box around the EGT readout of the cylinder with the hottest EGT. The Δ Peak temperature is the difference between the peak temperature and the present temperature for the peaked cylinder. When the first peak is detected, “1st” is annunciated below that cylinder’s EGT bar and the temperature is enclosed in a light blue box.

The system continues to detect peak EGTs for each cylinder lean of peak as the fuel flow is decreased, and the peak of each cylinder’s EGT is indicated by a light blue marker on the graph. Once all cylinders are lean of peak, the last cylinder to peak is denoted by the “Last” annunciation below its bar on the graph.

- Flight Instruments
- EIS
- Nav/Com/XPDR/Audio
- AFCS
- GPS Nav
- Flight Planning
- Procedures
- Hazard Avoidance
- Additional Features
- Abnormal Operation
- Annun/Alerts
- Appendix
- Index

Light Blue Box
Represents Peak

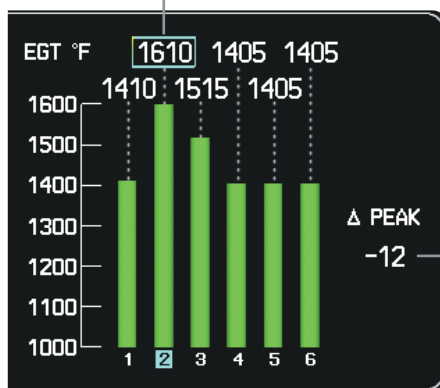

Temperature
Deviation
from Peak

Leaning Assist Mode

TKS FIKI Anti-ice System

In the default tank selection mode (AUTO), the system assures the fluid level in the two tanks is kept relatively even by periodically closing the tank with the lowest level. The system uses the TKS fluid tank quantity to control the tank shut-off valves. When the system is on and operating in AUTO mode, the shut-off valves close under the following conditions:

- The left and right tank level imbalance is greater than 0.25 gallons (low tank will be closed until level balance is within 0.15 gallons)
- The fluid quantity is empty (indicated from the fluid level sensor and level switch)
- The fluid quantity is unreliable (a miscompare between the level sensor and level switch or an out of range level sensor value)

Manual tank mode allows the pilot to control either tank's shut-off valve. Manual may be selected by pressing the **ANTI-ICE** Softkey to access the second-level softkeys **LEFT**, **AUTO**, and **RIGHT**.

- **LEFT** Softkey – opens left tank valve and closes right tank valve
- **AUTO** Softkey – returns to AUTO tank mode
- **RIGHT** Softkey – opens right tank valve and closes left tank valve

While operating in manual tank mode, only the selected/open tank's quantity is used for the range and endurance calculations.

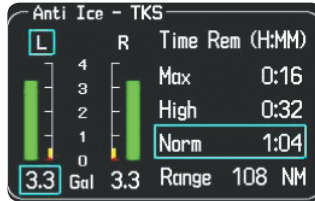

Manual Tank Mode (Left tank selected)

The TKS FIKI system consists of various operating modes, which are presented on the Perspective system. A white box highlights the active mode. Descriptions of the various modes are listed in the following table:

Operating Mode	System Operation	Comments
OFF	System Off	No modes selected
NORMAL	Both pumps operate on a timed, repeating cycle – 30 seconds ON and 90 seconds OFF	Provides 50% flow rate for light/moderate icing ☁
HIGH	A single primary pump (#1) operates continuously	Provides 100% flow rate for moderate icing ☁
MAX (momentary)	Both primary pumps operate continuously for 120 seconds	Provides 200% flow rate for severe icing or to expedite the removal of previous ice buildup ☁
PUMP BKUP	A single primary pump (#2) operates continuously	This mode is used in the event of a timer box failure or when BKUP mode is selected. Pump #2 provides 100% flow rate, bypassing the timer box ☁

☁ Refer to the pertinent flight manual for recommended pilot actions

- Flight Instruments
- EIS**
- Nav/Com/XPDR/Audio
- AFCS
- GPS Nav
- Flight Planning
- Procedures
- Hazard Avoidance
- Additional Features
- Abnormal Operation
- Annun/Alerts
- Appendix
- Index

- Flight Instruments
- EIS**
- Nav/Com/XPDR/Audio
- AFCs
- GPS Nav
- Flight Planning
- Procedures
- Hazard Avoidance
- Additional Features
- Abnormal Operation
- Annun/Alerts
- Appendix
- Index

Blank Page

NAV/COM/TRANSPONDER/AUDIO PANEL

DME TUNING

- 1) Press the **DME** Softkey.
- 2) Turn the large **FMS** Knob to select the DME source field.
- 3) Turn the small **FMS** Knob to select the desired Nav radio.
- 4) Press the **ENT** Key to complete the selection.

ENTER A TRANSPONDER CODE

- 1) Press the **XPDR** Softkey to display the transponder mode selection softkeys.
- 2) Press the **CODE** Softkey to display the transponder code selection softkeys, for digit entry.
- 3) Press the digit softkeys to enter the code in the Code Field or enter a code with the Numeric Keypad. When entering the code, the next key in sequence must be pressed within 10 seconds, or the entry is cancelled and restored to the previous code. Five seconds after the fourth digit has been entered, the transponder code becomes active.

Or:

- 1) Press the **XPDR** Key on the PFD/MFD Control Unit to select the transponder function.
- 2) Enter a code with the Numeric Keypad or **FMS** Knob on the PFD/MFD Control Unit. Five seconds after the fourth digit has been entered, the transponder code becomes active.

SELECTING A COM RADIO

Transmit/Receive

Press the **COM1 MIC (MIC1)** for GMA 350/350c), or **COM2 MIC (MIC2)** for GMA 350/350c) on the audio panel.

Receive Only

Press the **COM1**, or **COM2**, on the audio panel.

SELECTING A NAV RADIO

- 1) To begin navigating using a navigation radio, press the **CDI** Softkey on the PFD to select VOR1/LOC1 (NAV1) or VOR2/LOC2 (NAV2).
- 2) Press the **NAV1**, **NAV2**, **DME** (GMA 347 only), or **ADF** (GMA 347 only) Key on the audio panel to select or deselect the navigation radio audio source. All radio keys can be selected individually or together. On GMA 350/350c installs with optional DME and/or ADF to select audio press **AUX** key.

NAV/COM TUNING

- 1) Turn the respective tuning knobs to enter the desired frequency into the standby frequency field. The large knob enters MHz and the small knob enters kHz.
- 2) Press the appropriate **Frequency Transfer** Key to place the frequency into the active frequency field.
Or:
 - 1) Press the **COM** or **NAV** Key on the PFD/MFD Control Unit to select the desired COM or NAV frequency box.
 - 2) Turn the **FMS/XPDR COM/NAV** Knob to tune the desired frequency (large knob for MHz; small knob for kHz).
 - 3) Press the **Frequency Transfer** Key to transfer the frequency to the active field.

SPLIT COM

During Split COM operation, both the pilot and the copilot can transmit simultaneously over separate radios.

GMA 347

The pilot can still monitor NAV1, NAV2, ADF, DME, and MKR Audio as selected, but the copilot is only able to monitor COM2.

When Split COM operation is selected, COM1 is used by the pilot and COM2 is used by the copilot. The COM1 MIC Annunciator flashes when the pilot's microphone PTT is pressed. The COM2 MIC Annunciator flashes when the copilot's microphone PTT is pressed.

Pressing the **COM 1/2** Key selects Split COM operation. The COM 1/2 Annunciator is illuminated indicating Split COM operation. COM1 and COM2 frequencies are displayed in green indicating that both transceivers are active. Split COM operation is cancelled by pressing the **COM 1/2** Key again, at which time the annunciator is extinguished.

GMA 350/350c

Pressing both **MIC** Keys simultaneously initiates Split COM Mode (i.e., COM1/COM2). The respective COM1/MIC1 or COM2/MIC2 annunciators are illuminated indicating Split COM operation. Split COM operation is cancelled by pressing one of the selected MIC Keys again.

In Split COM mode, the pilot uses COM1 and the copilot uses COM2.

INTERCOM SYSTEM (ICS) ISOLATION

GMA 347

Press the **PILOT** and/or **COPLT** Key on the audio panel to select those isolated from hearing the Nav/Com radios and music.

PILOT KEY Annunciator	COPLT KEY Annunciator	Pilot Hears	Copilot Hears	Passenger Hears
OFF	OFF	Selected radios, aural alerts, pilot, copilot, passengers, music	Selected radios, aural alerts, pilot, copilot, passengers, music	Selected radios, aural alerts, pilot, copilot, passengers, music
ON	OFF	Selected radios, aural alerts, pilot	Copilot, passengers, music	Copilot, passengers, music
OFF	ON	Selected radios, aural alerts, pilot; passengers, music	Copilot	Selected radios, aural alerts, pilot, passengers, music
ON	ON	Selected radios, aural alerts, pilot, copilot	Selected radios, aural alerts, pilot, copilot	Passengers, music

ICS Isolation Modes

GMA 350/350c



NOTE: In the following modes the copilot position is configured as crew.



NOTE: In the default ICS configuration, only the pilot and copilot positions can hear aircraft alerts.

All Intercom Mode

In 'All Intercom' mode the Pilot, Copilot, and Passengers hear each other and hear the aircraft audio.



ICS Keys

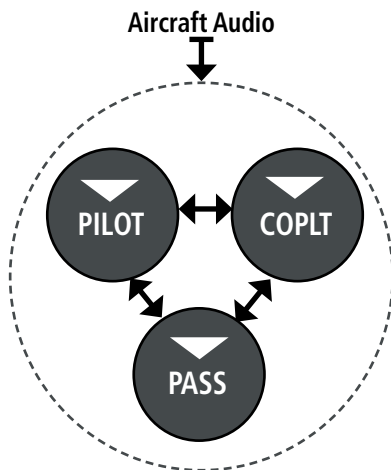

Mode Operation

- Flight Instruments
- EIS
- Nav/Com/XPDR/Audio
- AFCs
- GPS Nav
- Flight Planning
- Procedures
- Hazard Avoidance
- Additional Features
- Abnormal Operation
- Annun/Alerts
- Appendix
- Index

Pilot Isolate Mode

In ‘Pilot Isolate’ mode the Pilot, Copilot, and Passengers hear the aircraft audio. The Copilot and Passengers also hear each other.

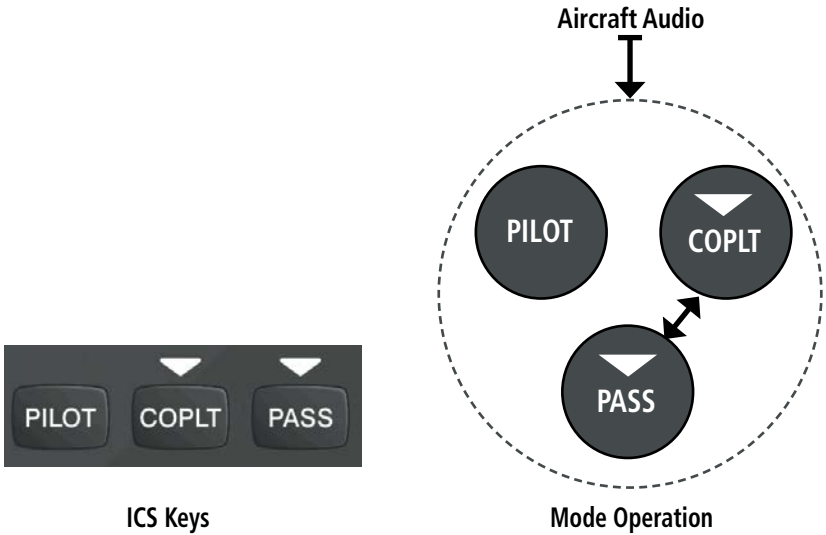

Passenger/Crew Isolate Mode

In ‘Passenger/Crew Isolate’ mode the Pilot and Copilot hear the aircraft audio and each other. The Passengers hear each other.

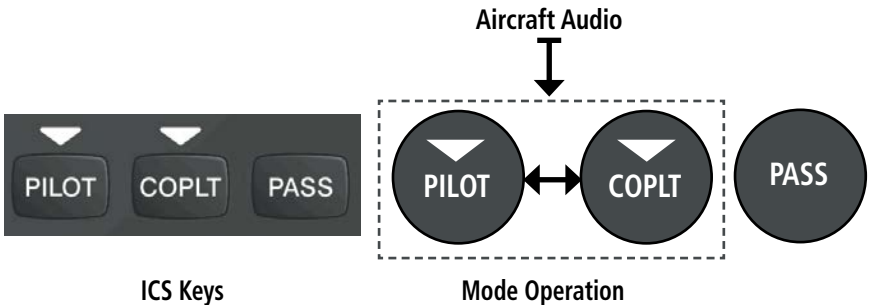

- Flight Instruments
- EIS
- Nav/Com/XPDR/Audio
- AFCS
- GPS Nav
- Flight Planning
- Procedures
- Hazard Avoidance
- Additional Features
- Abnormal Operation
- Annun/Alerts
- Appendix
- Index

Copilot Isolate Mode

In ‘Copilot Isolate’ mode the Pilot and Passengers hear the aircraft audio and each other. The Copilot has the option to use Split-COM mode.

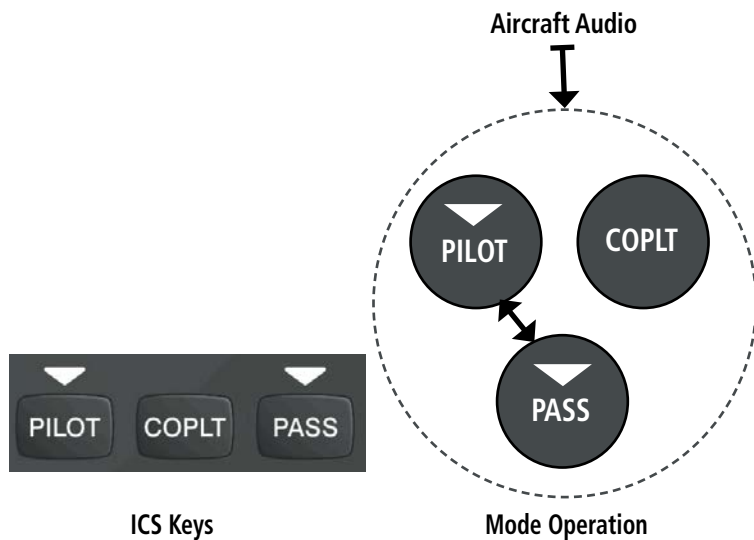

All Isolate Mode

In ‘All Isolate’ mode the Pilot hears the aircraft audio. The Copilot has the option to use Split-COM mode. The Passengers hear each other.

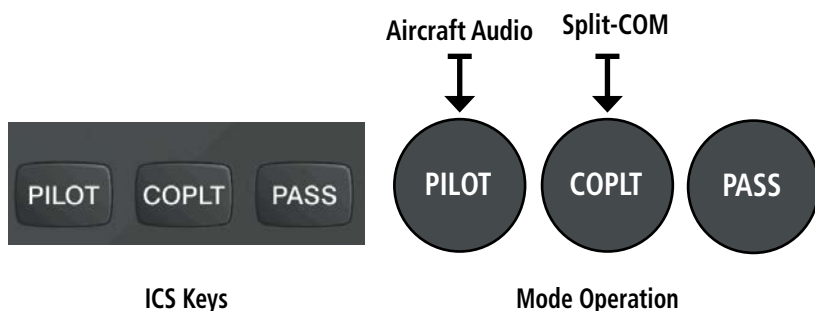

Pilot & Copilot Isolate Mode

In 'Pilot & Copilot Isolate' mode the Pilot and Passengers hear the aircraft audio. The Copilot has the option to use Split-COM mode.

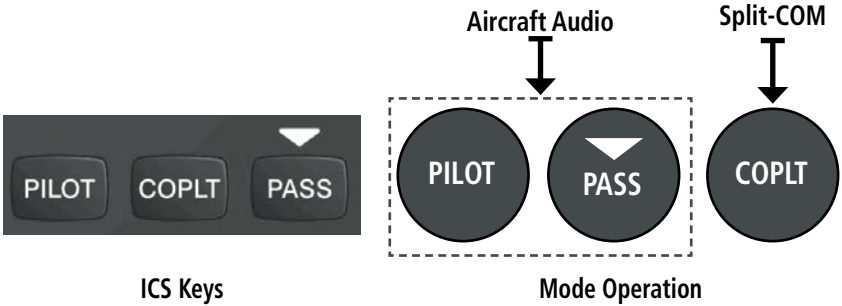

Pilot & Passenger Isolate Mode

In 'Pilot & Passenger Isolate' mode the Pilot and Copilot hear the aircraft audio. The Passengers hear each other.

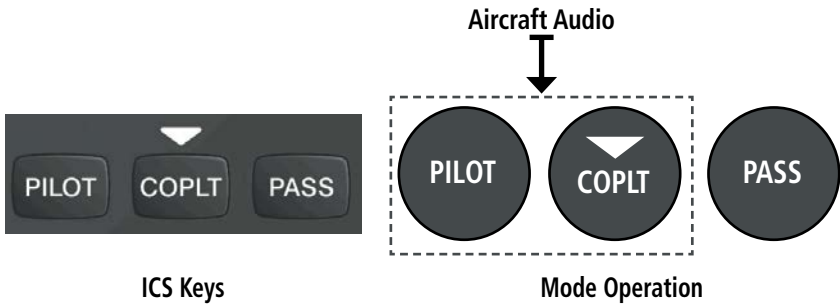

Copilot & Passenger Isolate Mode

In 'Copilot & Passenger Isolate' mode the Pilot can hear the aircraft audio. The Copilot has the option to use Split-COM mode. The Passengers hear each other.

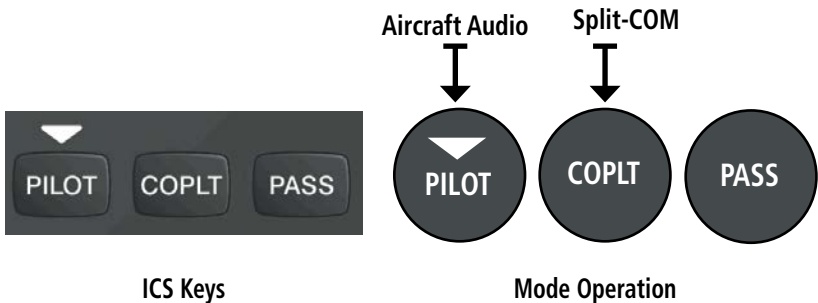

- Flight Instruments
- EIS
- Nav/Com/XPDR/Audio
- AFCS
- GPS Nav
- Flight Planning
- Procedures
- Hazard Avoidance
- Additional Features
- Abnormal Operation
- Annun/Alerts
- Appendix
- Index

TELEPHONE/ENTERTAINMENT AUDIO**GMA 347****Crew Music**

Crew music, either SiriusXM Radio or Music1, can be heard by the pilot and copilot when both the PILOT and the COPLT ICS Annunciators are extinguished. Crew music can also be heard by the pilot when the COPLT Annunciator is illuminated and by the copilot when the PILOT Annunciator is illuminated.

Music Muting

Crew music muting occurs when aircraft radio or marker beacon activity is heard. Crew music is always soft muted when an interruption occurs from these sources. Soft muting is the gradual return of music to its original volume level. The time required for music volume to return to normal is between one-half and four seconds.

Music Muting Enable/Disable

Pressing and holding the **MKR/MUTE** Key for three seconds switches crew music muting on and off. When switching, either one or two beeps are heard; one beep indicates that music muting is enabled, two beeps indicate music muting is disabled. Crew music muting is reset (enabled) during power up.

Passenger Music

Passenger music, either SiriusXM Radio or Music2, can be heard only by the passengers and is never soft muted.

SiriusXM Radio Entertainment

SiriusXM Radio audio from the Data Link Receiver may be heard by the pilot and passengers simultaneously (optional: requires subscription to SiriusXM Radio Service). Refer to the Additional Features Section for more details on the Data Link Receiver.

Connecting a stereo input to the audio jack removes the SiriusXM Radio Audio from that input.

GMA 350/350c

The telephone/entertainment () Key controls a telephone or entertainment device connected to the rear of the audio panel or to the Front Panel Jack.

The **MUS1** and **MUS2** Key controls the Entertainment Music audio input.

The Front Panel Jack can be used as an entertainment input or a telephone input (in which case, it disables the rear telephone interface). The Front Panel Jack is a 3.5-mm stereo jack that is compatible with popular portable entertainment devices such as MP3s, CD players, and cell phones. The headphone outputs of the entertainment devices can be plugged into the Front Panel Jack or the **MUS1** or **MUS2** external jacks.

The music (MUS1/MUS2) and telephone/entertainment () audio are distributed using the Blue-Select Mode.

The Blue-Select Mode is entered by pressing the small knob when the volume control cursor (flashing white annunciator) is not active. If the volume control cursor is active, press the small knob twice. The first press will cancel the volume control cursor, the second will activate Blue-Select Mode.

The annunciator over the ) Key will be flashing blue. Any combination of the annunciators over the **PILOT**, **COPLT**, and **PASS** buttons may be blue. Select the desired button to turn the blue annunciator on or off to distribute the telephone/entertainment audio to selected crew/passenger positions. Turn the large knob to select **MUS1** or **MUS2** and select the crew positions to receive the music audio.

Selecting any key other than **PILOT**, **COPLT**, **PASS**, **MUS1**, **MUS2**, or ) will cancel Blue-Select Mode. Pressing the small knob will also cancel Blue-Select Mode. After approximately ten seconds with no input, the Blue-Select Mode will automatically cancel.

Enabling/Disabling Muting

Press and hold the **MUS1**, **MUS2**, or () Key for two seconds to switch muting on and off. The aural message “**Mute Music on Reception Enabled/Disabled**” or “**Mute Tel and Jack on Reception Enabled/Disabled**” is heard.

3D AUDIO (GMA 350/350C ONLY)

Stereo headsets are needed using the 3D Audio feature. If 3D audio is activated when mono headsets are in use, the listener will still hear all audio sources; however, there is no benefit from location separation.

Press and hold the **PILOT** Key to enable 3D audio processing for all headset positions. When 3D Audio is enabled, the aural message “3D audio left” is heard in the left ear followed by “3D audio right” in the right ear. Press and hold the **PILOT** Key again to disable 3D audio processing for all headset positions.

BLUETOOTH® (GMA 350C ONLY)

Pairing a Bluetooth device with the GMA 350c

Press and hold the inner knob for two seconds. The Bluetooth Annunciator flashes to indicate the unit is discoverable and the aural message “**Bluetooth discoverable**” is heard. The GMA 350c will remain discoverable for 90 seconds or until a successful pair is established. Once paired, the Bluetooth Annunciator turns steady blue and the aural message “**Bluetooth connected/paired**” is heard.

Assigning an audio source to the Bluetooth device

Press the **MUS1**, or **MUS2** key until the annunciator turns blue (the audio from the Bluetooth source will not be heard until this step is complete). The key annunciator cycles OFF-WHITE-BLUE. WHITE selects the wired audio source. BLUE selects the Bluetooth audio source. The BLUE source assignment will persist through Bluetooth audio connection disruptions.

DIGITAL CLEARANCE PLAYER



NOTE: Only the audio for the selected **COM MIC** Key is recorded. Audio is not recorded for **COM3 MIC**.

- Pressing the **PLAY** Key once plays the latest recorded memory block, then returns to normal operation.
- Pressing the **MKR/MUTE** Key while playing a memory block stops play. If a COM input signal is detected during play of a recorded memory block, play is halted.
- Pressing the **PLAY** Key during play begins playing the previously recorded memory block. Each subsequent press of the **PLAY** Key begins playing the next previously recorded block.

AUTOMATIC FLIGHT CONTROL SYSTEM

GARMIN AFCS



NOTE: If sensor information (other than attitude) required for a flight director mode becomes invalid or unavailable, the flight director automatically reverts to the default mode for that axis.



NOTE: If the attitude information required for the default flight director modes becomes invalid or unavailable, the autopilot automatically disengages.

Flight Director Activation

An initial press of a key listed in the following table (when the flight director is not active) activates the flight director in the listed modes.

Control Pressed	Modes Selected			
	Lateral		Vertical	
FD Key	Roll Hold (default)	ROL	Pitch Hold (default)	PIT
AP Key	Roll Hold (default)	ROL	Pitch Hold (default)	PIT
GA Button	Takeoff (on ground)Go Around (in air)	TO GA	Takeoff (on ground)Go Around (in air)	TO GA
ALT Key	Roll Hold (default)	ROL	Altitude Hold	ALT
VS Key	Roll Hold (default)	ROL	Vertical Speed	VS
VNV Key	Roll Hold (default)	ROL	Vertical Path Tracking*	VPTH
NAV Key	Navigation**	GPS VOR LOC BC	Pitch Hold (default)	PIT
APR Key	Approach**	GPS VOR LOC	Pitch Hold (default)	PIT
HDG Key	Heading Select	HDG	Pitch Hold (default)	PIT
LVL Key	Level Hold	LVL	Level Hold	LVL

*Valid VNV flight plan must be entered before **VNV** Key press activates flight director.

The selected navigation receiver must have a valid VOR or LOC signal or active GPS course before **NAV or **APR** Key press activates flight director.

Vertical Modes

Vertical Mode	Description	Control	Annunciation	
Pitch Hold	Holds the current aircraft pitch attitude; may be used to climb/descend to the Selected Altitude	(default)	PIT	
Selected Altitude Capture	Captures the Selected Altitude	*	ALTS	
Altitude Hold	Holds the current Altitude Reference	ALT Key	ALT	nnnn FT
Vertical Speed	Maintains the current aircraft vertical speed; may be used to climb/descend to the Selected Altitude	VS Key	VS	nnnn FPM
Indicated Airspeed (IAS)	Maintains the current aircraft airspeed in IAS while the aircraft is climbing/descending to the Selected Altitude	IAS Key	IAS	nnn KT
Vertical Path Tracking (If equipped)	Captures and tracks descent legs of an active vertical profile	VNV Key	VPTH	
VNV Target Altitude Capture	Captures the Vertical Navigation (VNV) Target Altitude	**	ALTV	
Glidepath	Captures and tracks the SBAS glidepath on approach	APR Key	GP	
Glideslope	Captures and tracks the ILS glideslope on approach		GS	
Takeoff	Commands a constant pitch angle and wings level on ground in preparation for takeoff	GA Button	TO	
Go Around	Commands a constant pitch angle and wings level in the air		GA	
Level	Maintains the current vertical speed reference	LVL Button	LVL	

* ALTS armed automatically when PIT, VS, IAS, or GA active, and under VPTH when Selected Altitude is to be captured instead of VNV Target Altitude

** ALTV armed automatically under VPTH when VNV Target Altitude is to be captured instead of Selected Altitude

Lateral Modes

Lateral Mode	Description	Control	Annunciation
Roll Hold	Holds the current aircraft roll attitude or rolls the wings level, depending on the commanded bank angle	(default)	ROL
Heading Select	Captures and tracks the Selected Heading	HDG Key	HDG
Navigation, GPS	Captures and tracks the selected navigation source (GPS, VOR, LOC)	NAV Key	GPS
Navigation, VOR Enroute Capture/ Track			VOR
Navigation, LOC Capture/Track (No Glideslope)			LOC
Navigation, Backcourse Capture/ Track			BC
Approach, GPS	Captures and tracks the selected navigation source (GPS, VOR, LOC)	APR Key	GPS
Approach, VOR Capture/Track			VAPP
Approach, LOC Capture/Track (Glideslope Mode automatically armed)			LOC
Takeoff	Commands a constant pitch angle and wings level on ground in preparation for takeoff	GA Button	TO
Go Around	Commands a constant pitch angle and wings level in the air		GA
Level	Maintains wings level	LVL Button	LVL

Level



NOTE: The level function is not available when Automatic Descent Mode has been activated by the Hypoxia Detection System.

Pressing the **LVL** Key engages the autopilot (within autopilot engagement limits) and levels the aircraft in pitch (to arrest a climb or descent) and roll. No other lateral or vertical modes are engaged, therefore, the aircraft will not hold a course or heading and will not hold a selected altitude.

S-TEC FIFTY FIVE X AUTOPILOT (OPTIONAL)



NOTE: This status annunciation is not analogous to both Perspective and the S-TEC Fifty Five X. Refer to the approved S-TEC Fifty Five X Pilot's Operating Handbook (POH) for comprehensive list of annunciations and operating instructions.

In addition to the status and mode annunciations that are simultaneously displayed on both the Perspective system AFCS Status Box and the S-TEC Fifty Five X Autopilot Display and/or Remote Annunciator Display, the Perspective system displays an additional status annunciation of 'AP' when the autopilot is engaged. This provides the pilot with a dedicated annunciation showing the status of the autopilot engagement.

GPS NAVIGATION

DIRECT-TO NAVIGATION

Direct-to Navigation using the MFD

- 1) Press the **Direct-to** () Key on the PFD/MFD Control Unit.
- 2) Enter the waypoint identifier.
- 3) Press the **ENT** Key to confirm the identifier. The 'Activate?' field is highlighted.
- 4) If no altitude constraint or course is desired, press the **ENT** Key to activate. To enter an altitude constraint, proceed to step 5.
- 5) Turn the large **FMS** Knob to place the cursor over the 'VNV' altitude field.
- 6) Enter the desired altitude.
- 7) Press the **ENT** Key. If the waypoint entered is an airport, the option to select MSL or AGL is now displayed. If the waypoint is not an airport, proceed to step 9.
- 8) Turn the small **FMS** Knob to select 'MSL' or 'AGL'.
- 9) Press the **ENT** Key. The cursor is now flashing in the VNV offset distance field.
- 10) Enter the desired offset distance before (-) the waypoint.
- 11) Press the **ENT** Key. The 'Activate?' field is highlighted.
- 12) Press the **ENT** Key to activate.

Direct-to Navigation using the PFD

- 1) Press the **Direct-to** Key () on the PFD.
- 2) Turn the large **FMS** Knob to place the cursor in the desired selection field.
- 3) Turn the small **FMS** Knob to begin selecting the desired identifier, location, etc.
- 4) Press the **ENT** Key.
- 5) The cursor is now flashing on 'ACTIVATE?'. If no altitude constraint or course is desired, press the **ENT** Key to activate. To enter an altitude constraint, proceed to step 6.
- 6) Turn the large **FMS** Knob to place the cursor over the 'ALT' altitude field.

- 7) Turn the small **FMS** Knob to enter the desired altitude.
- 8) Press the **ENT** Key. If the waypoint entered is an airport, the option to select MSL or AGL is now displayed. If the waypoint is not an airport, proceed to step 10.
- 9) Turn the small **FMS** Knob to select 'MSL' or 'AGL'.
- 10) Press the **ENT** Key. The cursor is placed in the 'OFFSET' field.
- 11) Turn the small **FMS** Knob to enter the desired target altitude offset from the selected Direct-to.
- 12) Press the **ENT** Key to highlight 'Activate?' or turn the large **FMS** Knob to highlight the 'CRS' field.
- 13) Turn the small **FMS** Knob to enter the desired course to the waypoint.
- 14) Press the **ENT** Key to highlight 'ACTIVATE?'.
- 15) Press the **ENT** Key again to activate the Direct-to.

ACTIVATE A STORED FLIGHT PLAN

- 1) Press the **FPL** Key on the PFD/MFD Control Unit and turn the small **FMS** Knob to display the Flight Plan Catalog Page.
- 2) Press the **FMS** Knob to activate the cursor.
- 3) Turn the large **FMS** Knob to highlight the desired flight plan
- 4) Press the **ACTIVE** Softkey. The confirmation window is now displayed.
- 5) With 'OK' highlighted, press the **ENT** Key to activate the flight plan. To cancel the flight plan activation, turn the large **FMS** Knob to highlight 'CANCEL' and press the **ENT** Key.

ACTIVATE A FLIGHT PLAN LEG

- 1) From the Active Flight Plan Page, use the **Joystick** to position the Quick Select Box on the desired waypoint, or press the **FMS** Knob to activate the cursor and turn the large **FMS** Knob to highlight the desired waypoint.

- 2) Press the **ACT LEG** Softkey.

OR

Press the **MENU** Key, select the 'Activate Leg' option from the page menu and press the **ENT** Key. This step must be used when activating a leg from the PFD.

- 3) With 'Activate' highlighted, press the **ENT** Key.

STOP NAVIGATING A FLIGHT PLAN

- 1) Press the **FPL** Key on the PFD/MFD Control Unit to display the Active Flight Plan Page.
- 2) Press the **MENU** Key to display the Page Menu Window.
- 3) Turn the large **FMS** Knob to highlight 'Delete Flight Plan' and press the **ENT** Key. With 'OK' highlighted, press the **ENT** Key to delete the flight plan. This will not delete the stored flight plan, only the active flight plan.

VERTICAL NAVIGATION (VNAV)

The navigation database only contains altitudes for procedures that call for "Cross at" altitudes. If the procedure states "Expect to cross at," the altitude is not in the database. In this case the altitude may be entered manually.

ACTIVE FLIGHT PLAN			
KIXD / KDFW			
	DTK	DIS	ALT
KARLA	221°	11.7NM	13000FT
COVIE	221°	9.0NM	12400FT
LEMYN	220°	8.0NM	9900FT
Approach - KDFW-RNAV	17L	GPS LPV	
RIVET <i>iaf</i>	259°	18.8NM	4000FT
DRAAK	176°	3.3NM	2000FT
INWOD	176°	3.2NM	3000FT
MENOL <i>faf</i>	176°	3.9NM	2300FT
RW17L <i>map</i>	176°	5.3NM	
9900FT	174°	0.8NM	9900FT
POLKE			

Insertion Point Indicator → (points to RIVET *iaf*)

Quick Select Box → (points to RIVET *iaf*)

Large White Text (points to 13000FT)

Large Light Blue Text (points to 9900FT)

Small Light Blue Text (points to 4000FT)

Small Light Blue Subdued Text (points to 3000FT)

Small White Text with Altitude Restriction Bar (points to 9900FT)

5000FT Cross AT or ABOVE 5,000 ft

2300FT Cross AT 2,300 ft

3000FT Cross AT or BELOW 3,000 ft

Altitudes associated with approach procedures are “auto-designated”. This means the system automatically uses the altitudes loaded with the approach for giving vertical flight path guidance outside the FAF. Note these altitudes are displayed as small light blue text.

Altitudes associated with arrival procedures are “manually-designated”. This means the system does not use the altitudes loaded with the arrival for giving vertical flight path guidance until designated to do so by the pilot. Note that these altitudes are initially displayed as white text. These altitudes may be “designated” by placing the cursor over the desired altitude and pressing the **ENT** Key. After designation, the text changes to light blue.

Altitudes that have been designated for use in vertical navigation may also be made “non-designated” by placing the cursor over the desired altitude and pressing the **CLR** Key. The altitude is now displayed only as a reference. It will not be used to give vertical flight path guidance. Other displayed altitudes may change due to re-calculations or rendered invalid as a result of manually changing an altitude to a non-designated altitude.



NOTE: *Making course changes greater than 90° during a descent with vertical guidance may cause excessive and rapid movement of the vertical deviation indicator, and SVT Pathways.*

The system updates vertical path guidance continuously using ground speed and the calculated distance to the Bottom of Descent (BOD). Due to turn anticipation guidance (turn-smoothing), distance to the BOD can be affected by course changes greater than approximately 5 degrees. Ground speed can be affected by factors such as shifts in wind direction, aircraft power management, pitch angle, and course changes. Abrupt and/or substantial changes to either the distance to the BOD, ground speed, or both can cause similarly abrupt/substantial changes in vertical path guidance.

Because of turn-smoothing, changes to both distance to the BOD and ground speed tend to be more extreme when the BOD is also a waypoint that marks a large course change. These speed and distance changes will be accounted for in the computed required vertical path and reflected in the vertical guidance indications.

	White Text	Light Blue Text	Light Blue Subdued Text
Large Text	Altitude calculated by the system estimating the altitude of the aircraft as it passes over the navigation point. This altitude is provided as a reference and is not designated to be used in determining vertical flight path guidance.	Altitude has been entered by the pilot. Altitude is designated for use in giving vertical flight path. Altitude does not match the published altitude in navigation database or no published altitude exists.	The system cannot use this altitude in determining vertical flight path guidance.
Small Text	Altitude is not designated to be used in determining vertical flight path guidance. Altitude has been retrieved from the navigation database and is provided as a reference.	Altitude is designated for use in giving vertical flight path guidance. Altitude has been retrieved from the navigation database or has been entered by the pilot and matches a published altitude in the navigation database.	The system cannot use this altitude in determining vertical flight path guidance.

- Flight Instruments
- EIS
- Nav/Com/XPDR/Audio
- AFCs
- GPS Nav
- Flight Planning
- Procedures
- Hazard Avoidance
- Additional Features
- Abnormal Operation
- Annun/Alerts
- Appendix
- Index

- Flight Instruments
- EIS
- Nav/Com/XPDR/Audio
- AFCs
- GPS Nav**
- Flight Planning
- Procedures
- Hazard Avoidance
- Additional Features
- Abnormal Operation
- Annun/Alerts
- Appendix
- Index

Blank Page

FLIGHT PLANNING

TRIP PLANNING

- 1) Turn the large **FMS** Knob on the PFD/MFD Control Unit to select the 'AUX' page group.
- 2) Turn the small **FMS** Knob to select the Trip Planning Page.
- 3) The current 'PAGE MODE' is displayed at the top of the page: 'AUTOMATIC' or 'MANUAL'. To change the page mode, press the **AUTO** or **MANUAL** Softkey.
- 4) For Direct-to planning:
 - a) Press the **WPTS** Softkey and verify that the starting waypoint field indicates 'P.POS' (present position).
 - b) If necessary, press the **MENU** Key on the PFD/MFD Control Unit and select 'Set WPT to Present Position' to display 'P.POS'.
 - c) Press the **ENT** Key and the flashing cursor moves to the ending waypoint field.
 - d) Enter the identifier of the ending waypoint and press the **ENT** Key to accept the waypoint.

Or:

For point-to-point planning:

- a) Enter the identifier of the starting waypoint.
- b) Once the waypoint's identifier is entered, press the **ENT** Key to accept the waypoint. The flashing cursor moves to the ending waypoint.
- c) Again, enter the identifier of the ending waypoint.
- d) Press the **ENT** Key to accept the waypoint.

Or:

For flight plan leg planning:

- a) Press the **FPL** Softkey (at the bottom of the display).
- b) Turn the small **FMS** Knob to select the desired flight plan (already stored in memory), by number.
- c) Turn the large **FMS** Knob to highlight the 'LEG' field.

- d) Turn the small **FMS** Knob to select the desired leg of the flight plan, or select 'CUM' to apply trip planning calculations to the entire flight plan. Selecting 'FPL 00' displays the active flight plan. If an active flight plan is selected, 'REM' will be an available option to display planning data for the remainder of the flight plan.



NOTE: The page mode must be set to 'MANUAL' to perform the following steps.

- 5) Turn the large **FMS** Knob to highlight the departure time (DEP TIME) field.



NOTE: The departure time on the Trip Planning Page is used for preflight planning. Refer to the Utility Page for the actual flight departure time.

- 6) Enter the departure time. Press the **ENT** Key when finished. Departure time may be entered in local or UTC time, depending upon system settings.

- 7) The flashing cursor moves to the ground speed (GS) field. Enter the ground speed. Press the **ENT** Key when finished. Note that in 'automatic' page mode, ground speed is provided by the system.

- 8) The flashing cursor moves to the fuel flow field. Enter the fuel flow. Press the **ENT** Key when finished. Note that in 'AUTOMATIC' page mode, fuel flow is provided by the system.

- 9) The flashing cursor moves to the fuel onboard field. Enter the fuel onboard. Press the **ENT** Key when finished. Note that in 'AUTOMATIC' page mode, fuel onboard is provided by the fuel totalizer.

- 10) The flashing cursor moves to the calibrated airspeed (CALIBRATED AS) field. Enter the calibrated airspeed. Press the **ENT** Key when finished. Note that in 'AUTOMATIC' page mode, calibrated airspeed is provided by the system.

- 11) The flashing cursor moves to the altitude (IND ALTITUDE) field. Enter the altitude. Press the **ENT** Key when finished. Note that in 'AUTOMATIC' page mode, altitude is provided by the system.

- 12) The flashing cursor moves to the barometric setting (PRESSURE) field. Enter the desired baro setting. Press the **ENT** Key when finished. Note that in 'AUTOMATIC' page mode, the baro setting is provided by the setting entered on the PFD.

- 13) The flashing cursor moves to the air temperature (TOTAL AIR TEMP) field. Enter the desired air temperature. Press the **ENT** Key when finished. Note that in 'AUTOMATIC' page mode, air temperature is provided by the system outside air temperature.

CREATE A USER WAYPOINT DEFINED BY LATITUDE & LONGITUDE

- 1) Turn the large **FMS** Knob on the PFD/MFD Control Unit to select the 'WPT' page group.
- 2) Turn the small **FMS** Knob to select the User WPT Information Page.
- 3) Press the **NEW** Softkey. A waypoint is created at the current aircraft position.
- 4) Enter the desired waypoint name.
- 5) Press the **ENT** Key.
- 6) The cursor is now in the 'WAYPOINT TYPE' field. If desired, the waypoint can be made temporary (deleted automatically when the system is turned off). If the waypoint is to remain in the system, proceed to step 7.
 - a) Turn the large **FMS** Knob one click to the left to highlight 'TEMPORARY'.
 - b) Press the **ENT** Key to place a check-mark in the box. Turn the large **FMS** Knob to place the cursor back in the 'WAYPOINT TYPE' field.
- 7) With the cursor in the 'WAYPOINT TYPE' field, turn the small **FMS** Knob to display a list of waypoint types.
- 8) Turn the small **FMS** Knob to select LAT/LON (latitude and longitude).
- 9) Press the **ENT** Key.

CREATE A USER WAYPOINT DEFINED BY RADIALS FROM OTHER WAYPOINTS

- 1) Turn the large **FMS** Knob on the PFD/MFD Control Unit to select the 'WPT' page group.
- 2) Turn the small **FMS** Knob to select the User WPT Information Page.
- 3) Press the **NEW** Softkey. A waypoint is created at the current aircraft position.
- 4) Enter the desired waypoint name.
- 5) Press the **ENT** Key.

- 6) The cursor is now in the 'WAYPOINT TYPE' field. If desired, the waypoint can be made temporary (deleted automatically when the system is turned off). If the waypoint is to remain in the system, proceed to step 7.
 - a) Turn the large **FMS** Knob one click to the left to highlight 'TEMPORARY'.
 - b) Press the **ENT** Key to place a check-mark in the box. Turn the large **FMS** Knob to place the cursor back in the 'WAYPOINT TYPE' field.
- 7) With the cursor in the 'WAYPOINT TYPE' field, turn the small **FMS** Knob to display a list of waypoint types.
- 8) Turn the small **FMS** Knob to select RAD/RAD (radial/radial).
- 9) Press the **ENT** Key.
- 10) The cursor moves to the 'REFERENCE WAYPOINTS' field. With the first waypoint name highlighted, use the **FMS** Knobs to enter the desired waypoint name. Waypoints may also be selected as follows:
 - a) When a flight plan is active, turning the small **FMS** Knob to the left will display a list of the flight plan waypoints.
 - b) Turn the large **FMS** Knob to select the desired waypoint.
 - c) Press the **ENT** Key.

Or:

 - a) Turn the small **FMS** Knob to the left. Initially, a flight plan waypoint list is displayed.
 - b) Turn the small **FMS** Knob to the right to display the 'NRST' airports to the aircraft's current position.
 - c) Turn the large **FMS** Knob to select the desired waypoint.
 - d) Press the **ENT** Key.

Or:

 - a) Turn the small **FMS** Knob to the left. Initially, a flight plan waypoint list is displayed.
 - b) Turn the small **FMS** Knob to the right to display the 'RECENT' waypoints.
 - c) Turn the large **FMS** Knob to select the desired waypoint.
 - d) Press the **ENT** Key.

Or:

- a) Turn the small **FMS** Knob to the left. Initially, a flight plan waypoint list is displayed.
 - b) Turn the small **FMS** Knob to the right to display the 'USER' waypoints.
 - c) Turn the large **FMS** Knob to select the desired waypoint.
 - d) Press the **ENT** Key.
- 11) Press the **ENT** Key. The cursor is displayed in the 'RAD' (radial) field. Enter the desired radial from the reference waypoint.
 - 12) Press the **ENT** Key.
 - 13) Repeat step 10 to enter the next waypoint name.
 - 14) Press the **ENT** Key. The cursor is displayed in the 'RAD' (radial) field for the second waypoint. Enter the desired radial from the reference waypoint.
 - 15) Press the **ENT** Key.
 - 16) Press the **FMS** Knob to remove the flashing cursor.

CREATE A USER WAYPOINT DEFINED BY A RADIAL & DISTANCE FROM ANOTHER WAYPOINT

- 1) Turn the large **FMS** Knob on the PFD/MFD Control Unit to select the 'WPT' page group.
- 2) Turn the small **FMS** Knob to select the User WPT Information Page.
- 3) Press the **NEW** Softkey. A waypoint is created at the current aircraft position.
- 4) Enter the desired waypoint name.
- 5) Press the **ENT** Key.
- 6) The cursor is now in the 'WAYPOINT TYPE' field. If desired, the waypoint can be made temporary (deleted automatically when the system is turned off). If the waypoint is to remain in the system, proceed to step 7.
 - a) Turn the large **FMS** Knob one click to the left to highlight 'TEMPORARY'.
 - b) Press the **ENT** Key to place a check-mark in the box. Turn the large **FMS** Knob to place the cursor back in the 'WAYPOINT TYPE' field.
- 7) With the cursor in the 'WAYPOINT TYPE' field, turn the small **FMS** Knob to display a list of waypoint types.

- 8) Turn the small **FMS** Knob to select RAD/DIS (radial/distance).
- 9) Press the **ENT** Key.
- 10) The cursor moves to the 'REFERENCE WAYPOINTS' field. With the first waypoint name highlighted, use the **FMS** Knobs to enter the desired waypoint name. Waypoints may also be selected as follows:
 - a) When a flight plan is active, turning the small **FMS** Knob to the left will display a list of the flight plan waypoints.
 - b) Turn the large **FMS** Knob to select the desired waypoint.
 - c) Press the **ENT** Key.

Or:

 - a) Turn the small **FMS** Knob to the left. Initially, a flight plan waypoint list is displayed.
 - b) Turn the small **FMS** Knob to the right to display the 'NRST' airports to the aircraft's current position.
 - c) Turn the large **FMS** Knob to select the desired waypoint.
 - d) Press the **ENT** Key.

Or:

 - a) Turn the small **FMS** Knob to the left. Initially, a flight plan waypoint list is displayed.
 - b) Turn the small **FMS** Knob to the right to display the 'RECENT' waypoints.
 - c) Turn the large **FMS** Knob to select the desired waypoint.
 - d) Press the **ENT** Key.

Or:

 - a) Turn the small **FMS** Knob to the left. Initially, a flight plan waypoint list is displayed.
 - b) Turn the small **FMS** Knob to the right to display the 'USER' waypoints.
 - c) Turn the large **FMS** Knob to select the desired waypoint.
 - d) Press the **ENT** Key.
- 11) Press the **ENT** Key. The cursor is displayed in the 'RAD' (radial) field. Enter the desired radial from the reference waypoint.
- 12) Press the **ENT** Key.

- 13) The cursor is now displayed in the 'DIS' (distance) field. Enter the desired distance from the reference waypoint.
- 14) Press the **ENT** Key.
- 15) Press the **FMS** Knob to remove the flashing cursor.

CREATE A USER WAYPOINT USING THE MAP POINTER

- 1) Press the **Joystick** to activate the panning function and pan to the map location of the desired user waypoint.
- 2) Press the **ENT** Key. The User Waypoint Information Page is displayed with the captured position.



NOTE: If the pointer has highlighted a map database feature, one of three things happens upon pressing the **ENT** Key: 1) information about the selected feature is displayed instead of initiating a new waypoint, 2) a menu pops up allowing a choice between 'Review Airspaces' or 'Create User Waypoint', or 3) a new waypoint is initiated with the default name being the selected map item.

- 3) Enter a user waypoint name (up to six characters).
- 4) Press the **ENT** Key to accept the selected name.
- 5) If desired, define the type and location (i.e., LAT/LON, RAD/RAD or RAD/DIS) of the waypoint.
- 6) Press the **ENT** Key to accept the new waypoint.
- 7) If desired, change the storage method of the waypoint to "TEMPORARY" or "NORMAL" by moving the cursor to "TEMPORARY" and selecting the **ENT** Key to check or uncheck the box.
- 8) Press the **FMS** Knob to remove the flashing cursor.
- 9) Press the **GO BACK** Softkey to return to the map page.

DELETE A USER WAYPOINT

- 1) Turn the large **FMS** Knob on the PFD/MFD Control Unit to select the 'WPT' page group.
- 2) Turn the small **FMS** Knob to select the User WPT Information Page.
- 3) Press the **FMS** Knob to activate the cursor.
- 4) Turn the large **FMS** Knob to the place the cursor in the 'USER WAYPOINT LIST' field.

- 5) Turn the small **FMS** Knob to highlight the desired waypoint.
- 6) Press the **DELETE** Softkey.
- 7) The message 'Would you like to delete the user waypoint?' is displayed. With 'YES' highlighted, press the **ENT** Key.

SELECTING A VRP

- 1) With the WPT - VRP INFORMATION Page displayed, enter the identifier or the name of the VRP in the VRP Box.
- 2) Press the **ENT** Key.
- 3) Push the **FMS** Knob to remove the flashing cursor.

Or:

- 1) With the NRST - NEAREST VRP Page displayed, push the **FMS** Knob.
- 2) Press the **ENT** Key or turn either **FMS** Knob to select an identifier in the NEAREST VRP Box.
- 3) Push the **FMS** Knob to remove the flashing cursor.

CREATE A FLIGHT PLAN



NOTE: When creating a flight plan in the Active Flight Plan Window, the first leg is activated automatically after it is created.

Creating an active flight plan using the Quick Select Box (MFD only):

- 1) Press the **FPL** Key.
- 2) Begin entering the identifier of the departure waypoint using the PFD/MFD Control Unit's alphanumeric keys. The Waypoint Information Window is displayed as the identifier is entered.
- 3) Press the **ENT** Key. The Quick Select Box moves to the next empty field.
- 4) Repeat steps 2 and 3 to enter each additional flight plan waypoint. The active flight plan is modified as each waypoint is entered.

Creating an active flight plan using the cursor:

- 1) Press the **FPL** Key.

- 2) Press the **FMS** Knob to activate the cursor (only on MFD).
- 3) Turn the small **FMS** Knob to display the Waypoint Information Window. (Turning it clockwise displays a blank Waypoint Information Window, turning it counter-clockwise displays the Waypoint Information Window with a waypoint selection submenu allowing selection of active flight plan, nearest, recent, user, or airway waypoints).
- 4) Enter the identifier, facility, or city name of the departure waypoint or select a waypoint from the submenu of waypoints and press the **ENT** Key. The active flight plan is modified as each waypoint is entered.
- 5) Repeat step numbers 3 and 4 to enter each additional flight plan waypoint.
- 6) When all waypoints have been entered, press the **FMS** Knob to remove the cursor.

Creating a stored flight plan:

- 1) Press the **FPL** Key.
- 2) Turn the small **FMS** Knob clockwise to display the Flight Plan Catalog Page.
- 3) Select the **NEW** Softkey; or press the **MENU** Key, highlight 'Create New Flight Plan', and press the **ENT** Key to display a blank flight plan for the first empty storage location.
- 4) Turn the small **FMS** Knob to display the Waypoint Information Window. (Turning it clockwise displays a blank Waypoint Information Window, turning it counter-clockwise displays the Waypoint Information Window with a waypoint selection submenu allowing selection of active flight plan, nearest, recent, user, or airway waypoints).
- 5) Enter the identifier, facility, or city name of the departure waypoint or select a waypoint from the submenu of waypoints and press the **ENT** Key.
- 6) Repeat step numbers 4 and 5 to enter each additional flight plan waypoint.
- 7) When all waypoints have been entered, press the **FMS** Knob to return to the Flight Plan Catalog Page. The new flight plan is now in the list.

IMPORT A FLIGHT PLAN FROM AN SD CARD



NOTE: See the *Annunciations & Alerts* section for flight plan import message descriptions.

- 1) Insert the SD card containing the flight plan in the top card slot on the MFD.
- 2) Press the **FPL** Key on the PFD/MFD Control Unit to display the Active Flight Plan Page on the MFD.
- 3) Turn the small **FMS** Knob to select the Flight Plan Catalog Page.
- 4) Press the **FMS** Knob to activate the cursor.
- 5) Turn either **FMS** Knob to highlight an empty or existing flight plan.
- 6) Press the **IMPORT** Softkey.

If an empty flight plan is selected, a list of the available flight plans on the SD card will be displayed.

Or:

If an existing flight plan is selected, an 'Overwrite existing flight plan? OK or CANCEL' prompt is displayed. Press the **ENT** Key to choose to overwrite the selected flight plan and see a list of the available flight plans on the SD card. If overwriting the existing flight plan is not desired, select 'CANCEL' using the **FMS** Knob, press the **ENT** Key, select another existing or empty flight plan, and again press the **IMPORT** Softkey.

- 7) Turn the small **FMS** Knob to highlight the desired flight plan for importing.
- 8) Press the **ENT** Key.

INSERT A WAYPOINT IN THE ACTIVE FLIGHT PLAN**Insert waypoint using the Quick Select Box:**

- 1) Press the **FPL** Key on the PFD/MFD Control Unit to display the active flight plan.
- 2) Use the **Joystick** to move the Insertion Point Indicator to the location for the new waypoint in the flight plan list.
- 3) Begin entering the identifier of the new waypoint using the PFD/MFD Control Unit's alphanumeric keys. The Waypoint Information Window is displayed as the identifier is entered.
- 4) Press the **ENT** Key.

Insert waypoint using the cursor:

- 1) Press the **FPL** Key on the PFD/MFD Control Unit to display the active flight plan.
- 2) If necessary, press the **FMS** Knob to activate the cursor.
- 3) Turn the large **FMS** Knob to move cursor and Insertion Point Indicator (small light blue triangle) to the desired insertion point in the flight plan. The new waypoint is inserted before the highlighted waypoint.
- 4) Turn the small **FMS** Knob. The Waypoint Information Window is now displayed.
- 5) Enter the new flight plan waypoint by one of the following:
 - a) Enter the user waypoint identifier, facility, or city.
 - b) Press the **ENT** Key.

Or:

 - a) Turn the small **FMS** Knob to the left. Initially, a flight plan waypoint list is displayed.
 - b) Turn the small **FMS** Knob to the right to display the 'NRST' airport waypoints to the aircraft's current position.
 - c) Turn the large **FMS** Knob to select the desired waypoint.
 - d) Press the **ENT** Key.

Or:

 - a) Turn the small **FMS** Knob to the left. Initially, a flight plan waypoint list is displayed.
 - b) Turn the small **FMS** Knob to the right to display the 'RECENT' waypoints.
 - c) Turn the large **FMS** Knob to select the desired waypoint.
 - d) Press the **ENT** Key.
 - e) Press the **ENT** Key again to "accept" the waypoint.

ENTER AN AIRWAY IN A FLIGHT PLAN

Enter airway using the Quick Select Box:

- 1) Press the **FPL** Key on the PFD/MFD Control Unit to display the active flight plan.
- 2) Use the **Joystick** to move the Insertion Point Indicator to the desired entry point in the flight plan list.

- 3) Begin entering the identifier of the airway entry waypoint using the PFD/MFD Control Unit's alphanumeric keys. The Waypoint Information Window is displayed as the identifier is entered.
- 4) Press the **ENT** Key. The Quick Select Box and Insertion Point Indicator are now located following the newly entered waypoint.
- 5) Press the **MENU** Key and select "Load Airway" (required on the PFD). The Select Airway Page is displayed. The "Load Airway" menu item is available only when an acceptable airway entry waypoint has been entered in step 3 (the waypoint ahead of the Insertion Point Indicator).
- 6) Turn the **FMS** Knob to select the desired airway from the list, and press the **ENT** Key. Low altitude airways are shown first in the list, followed by "all" altitude airways, and then high altitude airways.
- 7) Turn the **FMS** Knob to select the desired airway exit point from the list, and press the **ENT** Key. 'LOAD?' is highlighted.
- 8) Press the **ENT** Key. The system returns to editing the flight plan with the new airway inserted.

Enter airway using the cursor:

- 1) Press the **FPL** Key on the PFD/MFD Control Unit.
- 2) Press the **FMS** Knob to activate the cursor (not required on the PFD).
- 3) Turn the large **FMS** Knob to move the cursor and Insertion Point Indicator (small light blue triangle) to the desired waypoint insertion point in the flight plan. If this waypoint is not a valid airway entry point, a valid entry point should be entered at this time.
- 4) Turn the small **FMS** Knob one click clockwise and press the **LD AIRWY** Softkey, or press the **MENU** Key and select "Load Airway" (required on the PFD). The Select Airway Page is displayed. The **LD AIRWY** Softkey or the "Load Airway" menu item is available only when an acceptable airway entry waypoint has been chosen (the waypoint ahead of the cursor position).
- 5) Turn the **FMS** Knob to select the desired airway from the list, and press the **ENT** Key. Low altitude airways are shown first in the list, followed by "all" altitude airways, and then high altitude airways.
- 6) Turn the **FMS** Knob to select the desired airway exit point from the list, and press the **ENT** Key. 'LOAD?' is highlighted.
- 7) Press the **ENT** Key. The system returns to editing the flight plan with the new airway inserted.

CREATING A USER-DEFINED HOLD AT AN ACTIVE FLIGHT PLAN WAYPOINT

- 1) Press the **FPL** Key to display the Active Flight Plan Page (MFD) or the Active Flight Plan Window (PFD).
- 2) Press the **FMS** Knob to activate the cursor (not required on the PFD) and turn the large **FMS** Knob to highlight the waypoint for the hold.
- 3) Press the **MENU** Key, highlight 'Hold At Wpt', and press the **ENT** Key. The HOLD AT window appears with the course field highlighted.
- 4) Use the **FMS** Knobs to edit the entry course, and press the **ENT** Key.
- 5) Use the small **FMS** Knob to select 'INBOUND' or 'OUTBOUND' course direction, and press the **ENT** Key.
- 6) Use the small **FMS** Knob to select 'TIME' or 'DIST' length mode, and press the **ENT** Key.
- 7) Use the **FMS** Knobs to edit the length, and press the **ENT** Key.
- 8) Use the small **FMS** Knob to select 'RIGHT' or 'LEFT' turn direction, and press the **ENT** Key.
- 9) Use the **FMS** Knobs to edit the Expect Further Clearance Time (EFC TIME), and press the **ENT** Key.
- 10) Press the **ENT** Key while 'LOAD?' is highlighted to add the hold into the flight plan.

EDITING A USER-DEFINED HOLD

- 1) Press the **FPL** Key to display the Active Flight Plan Page (MFD) or the Active Flight Plan Window (PFD).
- 2) Press the **FMS** Knob to activate the cursor (not required on the PFD) and turn the large **FMS** Knob to highlight the waypoint for the hold.
- 3) Press the **MENU** Key, highlight 'Edit Hold', and press the **ENT** Key. The HOLD AT window appears with the course field highlighted.
- 4) Use the **FMS** Knobs to edit the entry course, and press the **ENT** Key.
- 5) Use the small **FMS** Knob to select 'INBOUND' or 'OUTBOUND' course direction, and press the **ENT** Key.
- 6) Use the small **FMS** Knob to select 'TIME' or 'DIST' length mode, and press the **ENT** Key.
- 7) Use the **FMS** Knobs to edit the length, and press the **ENT** Key.

- 8) Use the small **FMS** Knob to select 'RIGHT' or 'LEFT' turn direction, and press the **ENT** Key.
- 9) Use the **FMS** Knobs to edit the Expect Further Clearance Time (EFC TIME), and press the **ENT** Key.
- 10) Press the **ENT** Key while 'UPDATE?' is highlighted to add the hold into the flight plan.

CREATING A USER-DEFINED HOLD AT THE AIRCRAFT PRESENT POSITION

- 1) Press the **FPL** Key to display the Active Flight Plan Page (MFD) or the Active Flight Plan Window (PFD).
- 2) Press the **MENU** Key, highlight 'Hold At Present Position', and press the **ENT** Key. The HOLD AT window appears with the Length mode highlighted.
- 3) Use the small **FMS** Knob to select 'TIME' or 'DIST' length mode, and press the **ENT** Key.
- 4) Use the **FMS** Knobs to edit the length, and press the **ENT** Key.
- 5) Use the small **FMS** Knob to select 'RIGHT' or 'LEFT' turn direction, and press the **ENT** Key.
- 6) Use the **FMS** Knobs to edit the Expect Further Clearance Time (EFC TIME), and press the **ENT** Key.
- 7) Press the **ENT** Key while 'ACTIVATE?' is highlighted to immediately activate the hold.

REMOVING A USER-DEFINED HOLD (CREATED AT THE AIRCRAFT P.POS)

- 1) Press the **FPL** Key to display the Active Flight Plan Page (MFD) or the Active Flight Plan Window (PFD).
- 2) Press the **FMS** Knob to activate the cursor (not required on the PFD) and turn the large **FMS** Knob to highlight the PPOS-H waypoint.
- 3) Press the **CLR** Key. A "Remove Holding Pattern?" confirmation window is displayed.
- 4) Select 'OK' and press the **ENT** Key. The holding pattern is removed from the active flight plan. Select 'CANCEL' and press the **ENT** Key to cancel the removal of the holding pattern.

REMOVING A USER-DEFINED HOLD (CREATED AT AN ACTIVE WAYPOINT)

- 1) Press the **FPL** Key to display the Active Flight Plan Page (MFD) or the Active Flight Plan Window (PFD).

- 2) Press the **FMS** Knob to activate the cursor (not required on the PFD) and turn the large **FMS** Knob to highlight the HOLD waypoint.
- 3) Press the **CLR** Key. A 'Remove Holding Pattern?' confirmation window is displayed.
- 4) Select 'OK' and press the **ENT** Key. The holding pattern is removed from the active flight plan. Select 'CANCEL' and press the **ENT** Key to cancel the removal of the holding pattern.

INVERT AN ACTIVE FLIGHT PLAN

- 1) Press the **FPL** Key to display the active flight plan.
- 2) Press the **MENU** Key to display the Page Menu.
- 3) Turn the large **FMS** Knob to highlight 'Invert Flight Plan'.
- 4) Press the **ENT** Key. The original flight plan remains intact in its flight plan catalog storage location.
- 5) With 'OK' highlighted, press the **ENT** Key to invert the flight plan.

REMOVE A DEPARTURE, ARRIVAL, APPROACH, OR AIRWAY FROM A FLIGHT PLAN

Remove using the Quick Select Box (active flight plan only):

- 1) Press the **FPL** Key on the PFD/MFD Control Unit to display the active flight plan.
- 2) Use the **Joystick** to move the Quick Select Box around the desired procedure name or airway in the flight plan.
- 3) Press the **CLR** Key to display a confirmation window.
- 4) With 'OK' highlighted, press the **ENT** Key to remove the selected procedure or airway.

Remove using the cursor:

- 1) Press the **FPL** Key to display the active flight plan. Press the **FMS** Knob to activate the cursor.

Or, for a stored flight plan:

- a) Press the **FPL** Key on the PFD/MFD Control Unit and turn the small **FMS** Knob to select the Flight Plan Catalog Page.
- b) Press the **FMS** Knob to activate the cursor.
- c) Turn the large **FMS** Knob to highlight the desired flight plan.
- d) Press the **EDIT** Softkey.

- 2) Turn the large **FMS** Knob to highlight the title for the approach, departure, arrival, or airway to be deleted. Titles appear in white directly above the procedure's waypoints.
- 3) Press the **CLR** Key to display a confirmation window.
- 4) With 'OK' highlighted, press the **ENT** Key to remove the selected procedure or airway.

STORE A FLIGHT PLAN

- 1) After creating a flight plan on either the PFD or MFD, it may be saved by pressing the **MENU** Key.
- 2) Turn the large **FMS** Knob to highlight 'Store Flight Plan' and press the **ENT** Key.
- 3) With 'OK' highlighted, press the **ENT** Key to store the flight plan.

EDIT A STORED FLIGHT PLAN

- 1) Press the **FPL** Key on the PFD/MFD Control Unit and turn the small **FMS** Knob to display the Flight Plan Catalog Page.
- 2) Press the **FMS** Knob to activate the cursor.
- 3) Turn the large **FMS** Knob to highlight the desired flight plan.
- 4) Press the **EDIT** Softkey.
- 5) Turn the large **FMS** Knob to place the cursor in the desired location.
- 6) Enter the changes, then press the **ENT** Key.
- 7) Press the **FMS** Knob to return to the Flight Plan Catalog Page.

DELETE A WAYPOINT FROM THE FLIGHT PLAN

Delete using the Quick Select Box (active flight plan only):

- 1) Press the **FPL** Key on the PFD/MFD Control Unit to display the active flight plan.
- 2) Use the **Joystick** to move the Quick Select Box around the desired waypoint to be deleted.
- 3) Press the **CLR** Key to display a confirmation window.
- 4) With 'OK' highlighted, press the **ENT** Key to remove the selected waypoint.

Delete using the cursor:

- 1) Press the **FPL** Key to display the active flight plan. Press the **FMS** Knob to activate the cursor.

Or, for a stored flight plan:

- a) Press the **FPL** Key on the PFD/MFD Control Unit and turn the small **FMS** Knob to select the Flight Plan Catalog Page.
 - b) Press the **FMS** Knob to activate the cursor.
 - c) Turn the large **FMS** Knob to highlight the desired flight plan.
 - d) Press the **EDIT** Softkey.
- 2) Turn the large **FMS** Knob to highlight the waypoint to be deleted.
 - 3) Press the **CLR** Key to display a 'REMOVE (Wpt Name)?' confirmation window.
 - 4) With 'OK' highlighted, press the **ENT** Key to remove the waypoint. To cancel the delete request, turn the large **FMS** Knob to highlight 'CANCEL' and press the **ENT** Key.
 - 5) When all changes have been made, press the **FMS** Knob to remove the cursor.

INVERT AND ACTIVATE A STORED FLIGHT PLAN

- 1) Press the **FPL** Key on the PFD/MFD Control Unit.
- 2) Turn the small **FMS** Knob to select the Flight Plan Catalog Page.
- 3) Press the **FMS** Knob to activate the cursor.
- 4) Turn the large **FMS** Knob to highlight the desired flight plan.
- 5) Press the **INVERT** Softkey. 'Invert and activate stored flight plan?' is displayed.
- 6) With 'OK' highlighted, press the **ENT** Key. The selected flight plan is now inverted and activated. The original flight plan remains intact in its flight plan catalog storage location.

COPY A FLIGHT PLAN

- 1) Press the **FPL** Key on the PFD/MFD Control Unit.
- 2) Turn the small **FMS** Knob to select the Flight Plan Catalog Page.
- 3) Press the **FMS** Knob to activate the cursor.
- 4) Turn the large **FMS** Knob to highlight the flight plan to be copied.
- 5) Press the **COPY** Softkey. A 'Copy to flight plan #?' confirmation window is displayed.
- 6) With 'OK' highlighted, press the **ENT** Key to copy the flight plan. To cancel, turn the large **FMS** Knob to highlight 'CANCEL' and press the **ENT** Key.

DELETE A FLIGHT PLAN

- 1) Press the **FPL** Key on the PFD/MFD Control Unit.
- 2) Turn the small **FMS** Knob to select the Flight Plan Catalog Page.
- 3) Press the **FMS** Knob to activate the cursor.
- 4) Turn the large **FMS** Knob to highlight the flight plan to be deleted.
- 5) Press the **DELETE** Softkey. A 'Delete flight plan #?' confirmation window is displayed.
- 6) With 'OK' highlighted, press the **ENT** Key to delete the flight plan. To cancel, turn the large **FMS** Knob to highlight 'CANCEL' and press the **ENT** Key.

GRAPHICAL FLIGHT PLAN CREATION (ACTIVE FLIGHT PLAN ONLY)

- 1) Press the **FPL** Key to display the Active Flight Plan Page on the MFD.
- 2) Use the **Joystick** to move the Insertion Point Indicator to the desired waypoint entry point in the flight plan list.
- 3) Press the **Joystick** to activate the map pointer. Use the **Joystick** to move the pointer to the desired point on the map to be inserted as a waypoint in the flight plan.
- 4) Select the **LD WPT** Softkey. The selected waypoint is inserted at the selected point. The default user waypoint naming is USR000, USR001, USR002, and so on.
- 5) To change the user waypoint name, follow the procedure for modifying a user waypoint.

EXPORT A FLIGHT PLAN TO AN SD CARD



NOTE: See the *Annunciations & Alerts* section for flight plan export message descriptions.

- 1) Insert the SD card into the top card slot on the MFD.
- 2) Press the **FPL** Key on the PFD/MFD Control Unit to display the Active Flight Plan Page on the MFD.
- 3) Turn the small **FMS** Knob to select the Flight Plan Catalog Page.
- 4) Press the **FMS** Knob to activate the cursor.

- 5) Turn the large **FMS** Knob to highlight the flight plan to be exported.
- 6) Press the **EXPORT** Softkey.
- 7) Press the **ENT** Key to confirm the export.

Flight Instruments

EIS

Nav/Com/XPDR/Audio

AFCs

GPS Nav

Flight Planning

Procedures

Hazard Avoidance

Additional Features

Abnormal Operation

Annun/Alerts

Appendix

Index

Blank Page

PROCEDURES

LOAD AND ACTIVATE A DEPARTURE PROCEDURE

- 1) Press the **PROC** Key.
- 2) Turn the large **FMS** Knob to highlight 'SELECT DEPARTURE'.
- 3) Press the **ENT** Key. The cursor is displayed in the 'DEPARTURE' field with a list of available departures.
- 4) Turn the large **FMS** Knob to highlight the desired departure.
- 5) Press the **ENT** Key. A list of runways may be displayed for the departure. If so, turn either **FMS** Knob to select the desired runway.
- 6) Press the **ENT** Key. The cursor is displayed in the 'TRANSITION' field with a list of available transitions.
- 7) Turn the large **FMS** Knob to highlight the desired transition.
- 8) Press the **ENT** Key.
- 9) With 'LOAD?' highlighted, press the **ENT** Key. The departure is active when the flight plan is active.

ACTIVATE A DEPARTURE LEG

Activate leg using the Quick Select Box:

- 1) Press the **FPL** Key on the PFD/MFD Control Unit to display the active flight plan.
- 2) Use the **Joystick** to move the Quick Select Box to the TO waypoint of the desired leg within the departure.
- 3) Press the **ACT LEG** Softkey. A confirmation window showing the selected leg is displayed.
- 4) With 'ACTIVATE' highlighted, press the **ENT** Key.

Activate leg using the cursor:

- 1) Press the **FPL** Key on the PFD/MFD Control Unit to display the active flight plan.
- 2) Press the **FMS** Knob to activate the cursor.

- 3) Turn the large **FMS** Knob to highlight the TO waypoint of the desired leg within the departure.
- 4) Press the **ACT LEG** Softkey. A confirmation window showing the selected leg is displayed.
- 5) With 'ACTIVATE' highlighted, press the **ENT** Key.

LOAD AN ARRIVAL PROCEDURE

- 1) Press the **PROC** Key.
- 2) Turn the large **FMS** Knob to highlight 'SELECT ARRIVAL'.
- 3) Press the **ENT** Key. The cursor is displayed in the 'ARRIVAL' field with a list of available arrivals.
- 4) Turn the large **FMS** Knob to highlight the desired arrival.
- 5) Press the **ENT** Key. A list of transitions is displayed for the selected arrival.
- 6) Turn either **FMS** Knob to select the desired transition.
- 7) Press the **ENT** Key. A list of runways may be displayed for the selected arrival.
- 8) Turn the large **FMS** Knob to highlight the desired runway.
- 9) Press the **ENT** Key.
- 10) With 'LOAD?' highlighted, press the **ENT** Key.
- 11) The arrival becomes part of the active flight plan.
- 12) If an altitude associated with a waypoint in an arrival procedure is to be used to calculate vertical guidance perform the following steps:
 - a) Press the **FMS** Knob to activate the cursor.
 - b) Turn the large **FMS** Knob to highlight the desired waypoint altitude.
 - c) Press the **ENT** Key to designate the altitude for use in giving vertical guidance.

ACTIVATE AN ARRIVAL LEG

Activate Arrival using the Quick Select Box:

- 1) Press the **FPL** Key on the PFD/MFD Control Unit to display the active flight plan.
- 2) Use the **Joystick** to move the Quick Select Box to the TO waypoint of the desired leg within the arrival.

- 3) Press the **ACT LEG** Softkey. A confirmation window showing the selected leg is displayed.
- 4) With 'ACTIVATE' highlighted, press the **ENT** Key.

Activate Arrival using the cursor:

- 1) Press the **FPL** Key on the PFD/MFD Control Unit to display the active flight plan.
- 2) Press the **FMS** Knob to activate the cursor.
- 3) Turn the large **FMS** Knob to highlight the TO waypoint of the desired leg within the arrival.
- 4) Press the **ACT LEG** Softkey. A confirmation window showing the selected leg is displayed.
- 5) With 'ACTIVATE' highlighted, press the **ENT** Key.

LOAD AND/OR ACTIVATE AN APPROACH PROCEDURE



NOTE: *If certain GPS parameters (SBAS, RAIM, etc.) are not available, some published approach procedures for the desired airport may not be displayed in the list of available approaches.*

- 1) Press the **PROC** Key.
- 2) Turn the large **FMS** Knob to highlight 'SELECT APPROACH'.
- 3) Press the **ENT** Key. A list of available approaches for the destination airport is displayed.
- 4) Turn either **FMS** Knob to highlight the desired approach.
- 5) Press the **ENT** Key. A list of available transitions for the selected approach procedure is now displayed.
- 6) Turn either **FMS** Knob to select the desired transition. The "Vectors" option assumes vectors will be received to the final course segment of the approach and will provide navigation guidance relative to the final approach course.
- 7) Press the **ENT** Key. The cursor moves to the MINIMUMS field.
- 8) If desired, the DA/MDA for the selected approach procedure may be entered and displayed on the PFD. Turn the small **FMS** Knob in the direction of the green arrow to change the display from OFF to BARO, or TEMP COMP.

- 9) Press the **ENT** Key. The cursor moves to the altitude field. Turn the small **FMS** Knob to enter the published DA/MDA for the selected approach procedure.
- 10) Press the **ENT** Key. If BARO, or OFF was selected step 8, proceed to step 11. If TEMP COMP was selected in step 8, the cursor moves to the 'TEMP AT...' field. Turn the small **FMS** Knob to enter the temperature at the destination airport. The temperature compensated altitude minimum is displayed below the previously enter minimum altitude value.
- 11) Press the **ENT** Key. 'LOAD? or ACTIVATE?' is now displayed with 'LOAD?' highlighted.
- 12) Turn the large **FMS** Knob to select either 'LOAD?' or 'ACTIVATE?'.
Selecting 'LOAD?' enters the selected approach procedure into the active flight plan, but is not currently active. Selecting 'ACTIVATE?' enters the selected approach procedure into the active flight plan and activates the first leg of the approach.
- 13) Press the **ENT** Key.

ACTIVATE AN APPROACH IN THE ACTIVE FLIGHT PLAN

- 1) Press the **PROC** Key.
- 2) Turn the large **FMS** Knob to highlight 'ACTIVATE APPROACH'.
- 3) Press the **ENT** Key.

ACTIVATE A VECTOR TO FINAL APPROACH FIX

- 1) Press the **PROC** Key.
- 2) Turn the large **FMS** Knob to highlight 'ACTIVATE VECTOR-TO-FINAL'.
- 3) Press the **ENT** Key.
- 4) The final approach course becomes the active leg.

ACTIVATE A MISSED APPROACH IN THE ACTIVE FLIGHT PLAN

- 1) Press the **PROC** Key.
- 2) Turn the large **FMS** Knob to highlight 'ACTIVATE MISSED APPROACH'.

- 3) Press the **ENT** Key. A confirmation window is displayed.
- 4) With 'ACTIVATE' highlighted, press the **ENT** Key.

Or:

Press the go-around button.

- 5) After activating the missed approach procedure, another approach procedure may be loaded.

APPROACH DOWNGRADES

Perspective SBAS GPS allows for flying LNAV, LNAV+V, LNAV/VNAV, LP, LP+V, and LPV approach service levels according to the published chart. The '+V' designation adds advisory vertical guidance for assistance in maintaining a constant vertical glidepath similar to an ILS glideslope on approach. This guidance is displayed on the system PFD in the same location as the ILS glideslope using a magenta diamond. Baro VNAV guidance is displayed on the system PFD in the same location as the ILS glideslope using a magenta pentagon. The active approach service level is annunciated on the HSI as shown in the following table:

HSI Annunciation	Description
LNAV	RNAV GPS approach using published LNAV minima
LNAV+V	RNAV GPS approach using published LNAV minima. Advisory vertical guidance is provided
L/VNAV (available only if SBAS available)	RNAV GPS approach using published LNAV/VNAV minima (downgrades to Baro VNAV if SBAS unavailable)
LP (available only if SBAS available)	RNAV GPS approach using published LP minima (downgrades to LNAV if SBAS unavailable)
LP+V (available only if SBAS available)	RNAV GPS approach using published LP minima Advisory vertical guidance is provided
LPV (available only if SBAS available)	RNAV GPS approach using published LPV minima (downgrades to Baro VNAV if SBAS unavailable)

TEMPERATURE COMPENSATED ALTITUDE

When temperature compensated altitude is enabled for the loaded approach, the altitudes associated with the approach waypoints are displayed in slanted text.

Approach - KCOS-RNAV GPS 35R LPV			
HABUK iaf	021°	5.7NM	9000 FT
FALUR	261°	4.7NM	8600 FT
CEGIX faf	351°	5.9NM	7800 FT
RW35R map	351°	5.1NM	
6368FT	348°	0.5NM	6368 FT
MOGAL mahp			10000 FT
HOLD	168°	6.0NM	

Altitudes Displayed Without Temperature Compensation

Approach - KCOS-RNAV GPS 35R LPV			
HABUK iaf	021°	5.7NM	8788 FT
FALUR	261°	4.7NM	8418 FT
CEGIX faf	351°	5.9NM	7679 FT
RW35R map	351°	5.1NM	
6368FT	348°	0.5NM	6355 FT
MOGAL mahp			9712 FT
HOLD	168°	6.0NM	

Altitudes Displayed With Temperature Compensation

Enabling temperature compensated altitude:

- 1) From the Active Flight Plan Page, press the **MENU** Key. The Page Menu is displayed.
- 2) Turn the **FMS** Knob to highlight 'Temperature Compensation'.
- 3) Press the **ENT** Key. The TEMPERATURE COMPENSATION Window is displayed.
- 4) Use the small **FMS** Knob to select the temperature at the <airport>. The compensated altitude is computed as the temperature is selected.
- 5) Press the **ENT** Key. 'ACTIVATE COMPENSATION?' is highlighted.
- 6) Press the **ENT** Key. The compensated altitudes for the approach are shown in the flight plan.

Disabling temperature compensated altitude:

- 1) From the Active Flight Plan Page, press the **MENU** Key. The Page Menu is displayed.
- 2) Turn the **FMS** Knob to highlight 'Temperature Compensation'.
- 3) Press the **ENT** Key. The TEMPERATURE COMPENSATION Window is displayed.
- 4) Press the **ENT** Key. 'CANCEL COMPENSATION?' is highlighted.
- 5) Press the **ENT** Key. The temperature compensated altitude at the FAF is cancelled.

HAZARD AVOIDANCE

CUSTOMIZING THE HAZARD DISPLAYS ON THE NAVIGATION MAP

- 1) With the Navigation Map Page displayed, press the **MENU** Key to display the Navigation Map Page Menu. The cursor flashes on the 'Map Setup' option.
- 2) Press the **ENT** Key. The Map Setup Menu is displayed. Turn the small **FMS** Knob to select 'Weather' to customize the display of weather features. Select 'Traffic' to customize the display of traffic.
- 3) Press the small **FMS** Knob to return to the Navigation Map Page.





STORMSCOPE® (OPTIONAL)



WARNING: The onboard lightning detection sensor (e.g., Stormscope) is not intended to be used for hazardous thunderstorm penetration. Weather information on the Perspective MFD is approved for weather avoidance only. Refer to the manufacturer's Pilot's Guide for detailed operation.

Displaying Stormscope Lightning Data on the Navigation Map Page

- 1) Press the **MAP** Softkey.
- 2) Press the **STRMSCP** Softkey. Press the **STRMSCP** Softkey again to remove Stormscope Lightning Data from the Navigation Map Page.

Lightning Age	Symbol
Strike is less than 6 seconds old	
Strike is between 6 and 60 seconds old	
Strike is between 1 and 2 minutes old	
Strike is between 2 and 3 minutes old	

Select 'Cell' or 'Strike' as the Stormscope Lightning Mode

- 1) Press the **MENU** Key (with the Navigation Map Page displayed).
- 2) Turn either **FMS** Knob to highlight 'Map Setup'.
- 3) Press the **ENT** Key.
- 4) Turn the small **FMS** Knob to highlight 'Weather'.

- 5) Press the **ENT** Key.
- 6) Turn the large **FMS** Knob to place the cursor in the 'STRMSCP MODE' field.
- 7) Turn the small **FMS** Knob to display the 'Cell/Strike' window.
- 8) Turn either **FMS** Knob to select 'Cell' or 'Strike'. Press the **ENT** Key.
- 9) Push the **FMS** Knob to return to the Navigation Map Page.

Clear Stormscope Lightning Data from the Navigation Map Page

- 1) Press the **MENU** Key (with the Navigation Map Page displayed).
- 2) Turn either **FMS** Knob to highlight the 'Clear Stormscope® Lightning' field and press the **ENT** Key.



NOTE: *If heading input is lost, strikes and/or cells must be cleared manually after the execution of each turn. This is to ensure that the strike and/or cell positions are depicted accurately in relation to the nose of the aircraft.*

Stormscope Page

- 1) Turn the large **FMS** Knob until the Map Page group is selected.
- 2) Turn the small **FMS** Knob select the Stormscope Page.

Change the Stormscope Lightning Mode Between 'Cell' and 'Strike'

- 1) Select the Stormscope Page.
- 2) Press the **MODE** Softkey. The **CELL** and **STRIKE** Softkeys are displayed. Press the **CELL** Softkey to display 'CELL' data or press the **STRIKE** Softkey to display 'STRIKE' data. 'CELL' or 'STRIKE' is displayed in the mode box located in the upper left corner of the Stormscope Page.



NOTE: *"Cell mode" uses a clustering program to identify clusters of electrical activity that indicate cells.*

Change the Viewing Mode Between 360° and 120°

- 1) Select the Stormscope Page.
- 2) Press the **VIEW** Softkey. The **360** and **ARC** Softkeys are displayed. Press the **360** Softkey to display a 360° viewing area or press the **ARC** Softkey to display a 120° viewing area.

Press the **CLEAR** Softkey to remove all Stormscope lightning data from the display.

SIRIUSXM WEATHER (OPTIONAL)



WARNING: Do not use data link weather information for maneuvering in, near or around areas of hazardous weather. Information contained within data link weather products may not accurately depict current weather conditions.

Changing the Weather Data Link Source to Display SiriusXM Weather

- 1) If necessary, turn the large **FMS** Knob to select the Map Page Group.
- 2) If necessary, turn the small **FMS** Knob to select the Weather Data Link (FIS-B, XM, or CNXT) Page.
- 3) Press the **MENU** Key.
- 4) If necessary, turn the large **FMS** Knob to highlight 'Display XM Weather' and press the **ENT** Key.

Displaying Weather on the XM Weather Data Link Page

- 1) Turn the large **FMS** Knob to select the Map Page Group.
- 2) Turn the small **FMS** Knob to select the Weather Data Link (XM or CNXT) Page.
- 3) If the page title contains 'CNXT', it will be necessary to change the data link weather source from Garmin Connex to SiriusXM Weather. Refer to the previous procedure to change the source.
- 4) Select the **LEGEND** Softkey to view the legends for the selected products. If necessary, turn either **FMS** Knob to scroll through the list. Press the small **FMS** Knob or the **ENT** Key to return to the map.

Displaying SiriusXM on the Navigation Map Page

- 1) Press the **MAP** Softkey.
- 2) Select the **NEXRAD-C**, **XM LTNG** and/or **METAR** Softkey to display the desired weather. Select the applicable softkey again to remove weather data from the Navigation Map Page.
- 3) Winds Aloft can be displayed in the Profile View by selecting the **PROFILE** Softkey.

Display METAR and TAF information on the Airport Information Page

- 1) Turn the large **FMS** Knob to select the WPT Page Group.
- 2) Turn the small **FMS** Knob to select the Airport Information Page.
- 3) Press the **WX** Softkey to display METAR and TAF text (METAR and TAF information is updated every 12 minutes).









Map Panning Information – Weather Data Link Page

- 1) Push in the **Joystick** to display the panning arrow.
- 2) Move the **Joystick** to place the panning arrow on AIRMETS, TFRs, METARs, SIGMETs, PIREPs or AIREPs.
- 3) Press the **ENT** Key to display pertinent information for the selected product.

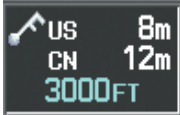
Note that pressing the **ENT** Key when panning over an AIRMET or a SIGMET displays an information box that shows the text of the report. Panning over an airport with METAR information does not display more information but allows the user to press the **ENT** Key and select that Airport's Information Page to display the text of the report. Pressing the **ENT** Key when panning over a TFR displays TFR specific information.

SiriusXM Weather Products and Symbols

Wx Product Status Icons	Description
US 3m CN 6m	NEXRAD - Available for the US and Canada. The age of the displayed data for each is shown at the right.
5m	ECHO TOP - The age of the displayed data is shown at the right. Not displayed when CLOUD TOP is displayed.
12m	CLOUD TOP - The age of the displayed data is shown at the right. Not displayed when ECHO TOP is displayed.
3m	XM LIGHTNING - The age of the displayed data is shown at the right.
2m	CELL MOVEMENT - The age of the displayed data is shown at the right.
SIGMET 2m AIRMET 5m	SIGMET & AIRMET - The age of the displayed data for each is shown at the right.

Wx Product Status Icons	Description
	METAR - Available for the US and Canada. The age of the displayed data for each is shown at the right.
	SURFACE ANALYSIS with CITY FORECAST - The upper symbol depicts Surface Analysis. The lower symbol depicts City Forecast. The age of the displayed data for each is shown at the right. The selected forecast period is shown at the bottom.
	FREEZING LEVEL - The age of the displayed data is shown at the right.
	WINDS ALOFT - Available for the US and Canada. The age of the displayed data for each is shown at the right. The altitude selection is shown at the bottom.
	COUNTY WARNING - The age of the displayed data is shown at the right.
	CYCLONE WARNING - The age of the displayed data is shown at the right.
	AIREP - The age of the displayed data is shown at the right.
	PIREP - The age of the displayed data is shown at the right. Urgent Pireps are displayed in yellow.
	TURBULENCE - The age of the displayed data is shown at the right. The altitude selection is shown at the bottom.
	ICING POTENTIAL - The age of the displayed data is shown at the right. The altitude selection is shown at the bottom.

CONNEX™ WEATHER (OPTIONAL)



WARNING: Do not use data link weather information for maneuvering in, near or around areas of hazardous weather. Information contained within data link weather products may not accurately depict current weather conditions.



WARNING: Do not use the indicated data link weather product age to determine the age of the weather information shown by the data link weather product. Due to time delays inherent in gathering and processing weather data for data link transmission, the weather information shown by the data link weather product may be significantly older than the indicated weather product age.

Weather data is provided when the pilot initiates either a manual or automatic Connex data request on the Connex Weather Data Link Page on the MFD. No weather data is displayed until the first Connex Weather Data Request is made.

Registering with Garmin Connex

A subscriber account must be established prior to receiving Connex Weather products. Contact Garmin Connex at <https://fly.garmin.com/fly-garmin/support/applications/satelliteservices/> or by calling 1-866-739-5687 in the United States or (011) 913-440-1135. The following information is required to register for Connex Weather services: System ID, GSR56 (GSR1/GSR2) Serial Number(s), Tail Number, Serial/Airframe Number, Country of Registration, Aircraft Manufacturer, and Aircraft Model.

- 1) Turn the large **FMS** Knob on the MFD to select the AUX page group.
- 2) Turn the small **FMS** Knob to select the AUX-SYSTEM STATUS. Note the System ID and GSR1/GSR2 Serial Number in the AIRFRAME field.

Activating Connex Weather Registration

After a subscriber account has been established, the system must be activated for Connex Weather. Activation is accomplished by entering the required access code. This process is only performed when initially setting up the system for Connex services.

- 1) Ensure the aircraft is outside and has a clear view of the sky.
- 2) Turn the large **FMS** Knob on the MFD to select the MAP page group.
- 3) Turn the small **FMS** Knob to select the MAP - WEATHER DATA LINK (CNXT or XM) Page. If 'XM' is displayed in the page title, it will be necessary to change the data link source to Garmin Connex (CNXT) before continuing. Refer to 'Viewing the Weather Data Link Page' procedure to change the data link source to Garmin Connex Weather prior to registration.
- 4) If the system displays the 'Connex Registration' window, proceed to step 7. Otherwise, press the **MENU** Key.

- 5) Turn the large **FMS** Knob to highlight 'Register With Connex' in the menu list.
- 6) Press the **ENT** Key. The Connex Registration window is displayed.
- 7) Enter the access code provided by customer service in the ACCESS CODE field.
- 8) Press the **ENT** Key. 'REGISTER' is highlighted.
- 9) Press the **ENT** Key. The system contacts the Garmin Connex service through the Iridium satellite network using the GSR 56. Registration is complete when the STATUS field displays 'REGISTERED'.

Changing the Weather Data Link Source to Display Connex Weather

- 1) If necessary, turn the large **FMS** Knob to select the Map Page Group.
- 2) If necessary, turn the small **FMS** Knob to select the Weather Data Link (FIS-B, XM, or CNXT) Page.
- 3) Press the **MENU** Key.
- 4) If necessary, turn the large **FMS** Knob to highlight 'Display Connex Weather' and press the **ENT** Key.

Accessing Connex Weather Products

- 1) Turn the large **FMS** Knob to select the Map Page Group.
- 2) Turn the small **FMS** Knob to select the Connex Weather Data Link Page.

When a weather product is selected for display on the Connex Weather Data Link Page, a box containing a symbol for the product and its age (in minutes) are shown in the upper right. If weather data has not been requested, 'N/A' is shown next to the product symbol instead of age. The age of the weather product is based on the time difference between when the data was assembled on the ground and the current GPS time. Weather products are updated continuously or refreshed at specific intervals (defined in the **Refresh Rate** column in the following table).

If for any reason, a weather product is not refreshed within the defined **Expiration Time** intervals, the data is considered expired and is removed from the display. The age of the expired product is replaced by dashes. If more than half of the expiration time has elapsed, the color of the product age readout changes to amber.

The refresh rate represents the interval at which the Connex servers make available the most current known weather data. It does not necessarily represent the rate at which new content is received from weather sources.

	Weather Product	Symbol	Expiration Time (Minutes)	Refresh Rate (Minutes)
Flight Instruments	Radar Precipitation (PRECIP)		30	U.S./Canada: 3* Europe: 15
EIS	Infrared Satellite (IR SAT)		60	30
Nav/Com/XPDR/Audio	Data Link Lightning (DL LTNG)		30	Continuous
AFCs	SIGMETs/AIRMETs (SIG/AIR)		60	Continuous
GPS Nav	Meteorological Aerodrome Report (METARs)		90	Continuous
Flight Planning	Winds Aloft (WIND)		60	Continuous
Procedures	Pilot Weather Report (PIREPs)		90	Continuous
Hazard Avoidance	Temporary Flight Restrictions (TFRs)	no product image	60	Continuous
	Terminal Aerodrome Reports (TAFs)	no product image	60	Continuous

* The composite precipitation image is updated every 3 minutes, but individual radar sites may take between 3 and 10 minutes to provide new data.

Setting Up and Customizing the Weather Data Link (CNXT) Page

- 1) Select the Weather Data Link (CNXT) Page.
- 2) Press the **MENU** Key.
- 3) With 'Weather Setup' highlighted, press the **ENT** Key.
- 4) Turn the small **FMS** Knob to select 'Product Group 1' or 'Product Group 2', and press the **ENT** Key.
- 5) Turn the large **FMS** Knob or press the **ENT** Key to scroll through product selections.
- 6) Turn the small **FMS** Knob to scroll through options for each product (ON/OFF, range settings, etc.).

- 7) Press the **ENT** Key to select an option.
- 8) Press the **FMS** Knob or **CLR** Key to return to the Weather Data Link (CNXT) Page with the changed settings.

Restoring Default Weather Data Link (CNXT) Page Settings

- 1) Select the Weather Data Link (CNXT) Page.
- 2) Press the **MENU** Key.
- 3) With 'Weather Setup' highlighted, press the **ENT** Key.
- 4) Press the **MENU** Key.
- 5) Highlight the desired default(s) to restore (all or for selection) and press **ENT** Key.

Viewing Legends for Displayed Weather Products

- 1) Select the Weather Data Link (CNXT) Page.
- 2) Select the **LEGEND** Softkey to display the legends for the displayed weather products.
Or:
 - a) Press the **MENU** Key.
 - b) Select 'Weather Legend' and press the **ENT** Key.
- 3) Turn the **FMS** Knob to scroll through the legends if more are available than fit in the window.
- 4) To remove the Legend Window, select the **LEGEND** Softkey, the **ENT** or the **CLR** Key, or press the **FMS** Knob.

Setting Up and Customizing Weather Data for the Navigation Map Page

- 1) Select the Navigation Map Page.
- 2) Press the **MENU** Key.
- 3) With 'Map Setup' highlighted, press the **ENT** Key.
- 4) Turn the small **FMS** Knob to select the 'Weather' Group and press the **ENT** Key.
- 5) Turn the large **FMS** Knob or press the **ENT** Key to scroll through product selections.

- 6) Turn the small **FMS** Knob to scroll through options for each product (ON/OFF, range settings).
- 7) Press the **ENT** Key to select an option.
- 8) Press the **FMS** Knob or **CLR** Key to return to the Navigation Map Page with the changed settings.

Connex Weather Data Requests

The Connex Data Request window provides the flight crew with the options to define the requested weather coverage area(s), choose automatic weather update intervals (if desired), and the ability to send or cancel weather data requests. The window also displays the status of the Connex data request process.

Requesting Connex Weather Data Manually

- 1) Select the Weather Data Link (CNXT) Page.
- 2) Press the **MENU** Key.
- 3) With 'Connex Data Request' highlighted, press the **ENT** Key.
- 4) Turn the large **FMS** Knob to highlight the desired coverage option(s) and press the **ENT** Key to select or deselect one of more of the following coverage selections:
 - PRESENT POSITION – Requests data based on current location.
 - DESTINATION – Requests data based on the active flight plan destination (Direct-To destinations excluded). See the Flight Management section for more information about entering and activating flight plans.
 - FPL – Requests data along an active flight plan, if one exists. Turn the small **FMS** Knob to select the desired flight plan look-ahead distance option (or choose 'REMAINING FPL' to request the remainder of the flight plan), then press the **ENT** Key.
 - WAYPOINT – Requests data based on a waypoint (which may be off-route). Turn the large and small **FMS** Knobs to enter a waypoint, then press the **ENT** Key.
- 5) Turn the large **FMS** Knob highlight to the 'DIAMETER / RTE WIDTH' (diameter/route width) distance field and turn the small **FMS** Knob to select the desired diameter and route width of the request, then press the **ENT** Key.

- 6) Turn the large **FMS** Knob until the 'SEND REQ' button is highlighted. Press the **ENT** Key to initiate the request immediately or press the **FMS** Knob to return to the Weather Data Link (CNXT) Page without requesting weather data.

During a Connex Data Request, the Request Status box initially displays "Contacting Connex...". Once a connection is established, the Request Status Box displays "Receiving Wx Data... Time Remaining:" with an estimated data transfer time (either minutes or seconds). If desired, the Connex Data Request window may be closed while the data request is processing by pressing the **FMS** Knob; the data request will continue to process in the background. Connex Data Requests typically take between 1 to 4 minutes to complete depending on the size of the selected weather coverage area and Iridium signal strength.

The system retrieves all available Connex Weather products within the selected coverage area during an initial Connex Data Request, regardless of which products (if any) are currently enabled for display. On subsequent requests, previously retrieved textual data (such as METARs and TAFs) is retained if it has not expired, while new textual weather data matching the current coverage area and all graphical weather data is downloaded during every data request.

If the system cannot complete a Connex weather data request, one or more messages will appear in the request status window as shown in the following table.

Weather Request Status Message	Description
Auto requests inhibited Send manual request to reset.	The system has disabled automatic weather data requests due to excessive errors. Automatic weather data requests have stopped. Send a manual weather data request to resume automatic updates.
Auto update retry: ## Seconds	The system will attempt another automatic weather data request after an error occurred during the previous request. Timer counts down until the next automatic request occurs.
Connex Comm Error [2]	A communications error has occurred with the GIA. The system should be serviced.
Connex Comm Error [4]	This occurs if multiple automatic weather data requests have recently failed, or the GDL 59 or a GIA is off-line.
Connex Comm Error [5]	The Iridium or Connex networks are not accessible. Check Iridium signal strength. If this error persists, the system should be serviced.

Weather Request Status Message	Description
Connex Comm Error [6]	A communications error has occurred. If this error persists, the system should be serviced.
Connex Comm Error [7]	A weather data transfer has timed out. Check Iridium signal strength and re-send the data request.
Connex Comm Error [8]	A server error has occurred or invalid data received.
Connex Login Invalid	There is a problem with the Connex registration. Contact Garmin Connex at 1-866-739-5687 in the United States or (011) 913-440-1135 for assistance.
Connex Server Temporarily Inop	The Connex weather data server is temporarily out of service, but is expected to return to service in less than 30 minutes.
Connex Server Inop	The Connex weather data server will be out of service for at least 30 minutes.
Invalid Coverage Area	The weather data request coverage area does not contain at least one of the following: a waypoint, a flight plan, or a flight plan destination. Verify at least one of the coverage options is enabled (checked) and contains required criteria, then re-send the data request.
No Connex Subscription	The system is not currently subscribed to Connex, or the access code is incorrect. Verify the access code. Contact Garmin Connex at 1-866-739-5687 in the United States or (011) 913-440-1135 for assistance.
Reduce Request Area	The Connex weather data request area exceeds size limits. Reduce weather coverage area and re-send data request.
Request Cancelled	The user has cancelled a Connex weather data request.
Requested area too large. Reduce coverage area.	The size of the Connex weather data request has exceeded limits. Reduce the size of the coverage area and try the weather data request again.
Request Failed - Try Again	The weather data request timed-out. Re-send data request.
Transfer Preempted	The data link is busy. Retry request later.

Canceling a Connex Weather Data Request in Progress

- 1) Select the Weather Data Link (CNXT) Page.
- 2) Press the **MENU** Key.
- 3) With 'Connex Data Request' highlighted, press the **ENT** Key.
- 4) Turn the large **FMS** Knob to select 'CANCEL REQ' and press the **ENT** Key. The request status box indicates 'Request Cancelled'.
- 5) Press the **FMS** Knob to return to the Weather Data Link (CNXT) Page.

Enabling Automatic Connex Data Requests

- 1) Select the Weather Data Link (CNXT) Page.
- 2) Press the **MENU** Key.
- 3) With 'Connex Data Request' highlighted, press the **ENT** Key.
- 4) Choose the desired weather coverage options.
- 5) Turn the large **FMS** Knob to select the 'UPDATE RATE' setting. Then turn the small **FMS** Knob to highlight the desired automatic update frequency (OFF, 5 Min, 10 Min, 15 Min, 20 Min, 25 Min, 30 Min, 45 Min, or 60 Min), then press the **ENT** Key.
- 6) The 'SEND REQ' button is highlighted and a countdown timer is displayed in the 'REQUEST STATUS' based on the currently selected update rate. Press the **ENT** Key to immediately send an immediate Connex Data Request.

Or:

Press the **FMS** Knob to return to the Weather Data Link (CNXT) Page.

Connex Weather Products

Precipitation

Precipitation data is not real-time. The lapsed time between collection, processing, and dissemination of radar images can be significant and may not reflect the current radar synopsis. Due to the inherent delays and the relative age of the data, it should be used for long-range planning purposes only.



NOTE: *Precipitation data cannot be displayed on the Navigation Map Page at the same time as terrain.*

Displaying Precipitation Weather Information

- 1) Select the **MAP** Softkey (for the PFD Inset Map, select the **INSET** Softkey). This step is not necessary on the Weather Data Link (CNXT) Page.
- 2) Press the **PRECIP** Softkey.

Radar data shown represents lowest level, base reflectivity, of radar returns. The display of the information is color-coded to indicate the weather severity level. All weather product legends can be viewed on the Connex Weather Data Link Page. For the Precipitation legend, select the **LEGEND** Softkey when Precipitation is selected for display.

Precipitation Limitations

Radar images may have certain limitations:

- Radar base reflectivity does not provide sufficient information to determine cloud layers or precipitation characteristics (wet hail vs. rain). For example, it is not possible to distinguish between wet snow, wet hail, and rain.
- Radar base reflectivity is sampled at the minimum antenna elevation angle. An individual radar site cannot depict high altitude storms at close ranges. It has no information about storms directly over the site.
- When zoomed in to a range of 30 nm, each square block on the display represents an area of four square kilometers.

The following may cause abnormalities in displayed radar images:

- Ground clutter
- Strokes and spurious radar data
- Sun strobes (when the radar antenna points directly at the sun)
- Interference from buildings or mountains, which may cause shadows
- Metallic dust from military aircraft, which can cause alterations in radar scans

Infrared Satellite

Infrared Satellite (IR SAT) data depicts cloud top temperatures from satellite imagery. Brighter cloud top colors indicate cooler temperatures occurring at higher altitudes.

Displaying Cloud Tops information:

- 1) Select the Weather Data Link (CNXT) Page.
- 2) Select the **IR SAT** Softkey.

To display the Infrared Satellite legend, select the **LEGEND** Softkey when Infrared Satellite data is selected for display.

Data Link Lightning

Lightning data shows the approximate location of cloud-to-ground lightning strikes. A strike icon represents a strike that has occurred within a two-kilometer region. Neither cloud-to-cloud nor the exact location of the lightning strike is displayed.

If the aircraft is also equipped with an on-board lightning detection system (e.g., L-3 WX-500 Stormscope®), only one lightning product may be enabled for display at a time.

Displaying Data Link Lightning information:

- 1) Select the **MAP** Softkey (for the PFD Inset Map, select the **INSET** Softkey). This step is not necessary on the Weather Data Link (CNXT) Page.
- 2) Select the **DL LTNG** Softkey.

To display the Data Link Lightning legend on the Weather Data Link Page, select the **LEGEND** Softkey when Data Link Lightning is selected for display.

SIGMETs and AIRMETs

The entire SIGMET or AIRMET is displayed as long as any portion of it is occurring within the coverage area of the Connex data request.

Displaying SIGMETs and AIRMETs:

- 1) Select the Weather Data Link (CNXT) Page.
- 2) Select the **SIG/AIR** Softkey.
- 3) To view the text of the SIGMET or AIRMET, press the **Joystick** and move the Map Pointer over the icon.
- 4) Press the **ENT** key.

To display the SIGMET and AIRMET legend, select the **LEGEND** Softkey when SIGMETs and AIRMETs are selected for display.

METARs and TAFs



NOTE: METAR information is only displayed within the installed navigation database service area.

METAR and TAF text are displayed on the WPT-Weather Information Page. TAF information is displayed in its raw form when it is available.

Displaying METAR and TAF text:

- 1) On the Weather Data Link (CNXT) Page, select the **METAR** Softkey.
- 2) Press the **Joystick** and pan to the desired airport.
- 3) Press the **ENT** Key. The Weather Information Page is shown with METAR and TAF text.
- 4) Use the **FMS** Knob or the **ENT** Key to scroll through the METAR and TAF text. METAR text must be completely scrolled through before scrolling through the TAF text.
- 5) Press the **FMS** Knob or the **CLR** Key to return to the Weather Data Link (CNXT) Page.

Or:

- 1) Select the Weather Information Page.
 - a) Turn the large **FMS** Knob to select the Waypoint Page Group.
 - b) Select the **WX** Softkey to select the Weather Information Page.
- 2) Press the **FMS** Knob to display the cursor.
- 3) Use the **FMS** Knob to enter the desired airport and press the **ENT** Key.
- 4) Use the **FMS** Knob or the **ENT** Key to scroll through the METAR and TAF text. Note that the METAR text must be completely scrolled through before scrolling through the TAF text.

To display the METAR legend on the Connex Weather Data Link Page, select the **LEGEND** Softkey when METARs are selected for display.

Winds Aloft

Winds Aloft data shows the forecasted wind speed and direction at the surface and at selected altitudes. Altitude can be displayed in 3,000-foot increments up to 42,000 feet MSL.

Displaying Winds Aloft data:

- 1) Select the Weather Data Link (CNXT) Page.
- 2) Press the **MORE WX** Softkey.
- 3) Press the **WIND** Softkey.
- 4) Select the desired altitude level: SFC (surface) up to 42,000 feet. Select the **NEXT** or **PREV** Softkey to cycle through the altitude softkeys. The **WIND** Softkey label changes to reflect the altitude selected.

To display the Winds Aloft legend, select the **LEGEND** Softkey when Winds Aloft is selected for display.

PIREPs

Pilot Weather Reports (PIREPs) describe in-flight weather encountered by pilots. A PIREP may contain unforecast adverse weather conditions, such as low in-flight visibility, icing conditions, wind shear, turbulence, and type of aircraft flown. PIREPs are issued as either Routine (UA) or Urgent (UUA).

Displaying PIREP text:

- 1) Select the Weather Data Link (CNXT) Page.
- 2) Press the **MORE WX** Softkey.
- 3) Press the **PIREPS** Softkey.
- 4) Press the **Joystick** and pan to the desired weather report. A gray circle will appear around the weather report when it is selected.
- 5) Press the **ENT** Key. The PIREP is first displayed in a decoded fashion, followed by the original text. Note the original text may contain additional information not found in the decoded version.
- 6) Use the **FMS** Knob or the **ENT** Key to scroll through the PIREP text.
- 7) Press the **FMS** Knob or the **CLR** Key to close the PIREP text window and return to the Weather Data Link (CNXT) Page.

To display the PIREP or AIREP legend, select the **LEGEND** Softkey when PIREPs or AIREPs are selected for display.

The PIREP color is determined by the type (routine or urgent).

FIS-B WEATHER



WARNING: Do not use data link weather information for maneuvering in, near, or around areas of hazardous weather. Information contained within data link weather products may not accurately depict current weather conditions.



WARNING: Do not use the indicated data link weather product age to determine the age of the weather information shown by the data link weather product. Due to time delays inherent in gathering and processing weather data for data link transmission, the weather information shown by the data link weather product may be significantly older than the indicated weather product age.

The optional GDL 88 receives Flight Information Services - Broadcast (FIS-B) weather data from a network of UAT ground-based transceivers (GBTs).

FIS-B weather data reception requires the aircraft being within range and line-of-sight of an operating GBT broadcasting FIS-B weather data. Reception may be affected by factors including altitude or terrain.

Reception of FIS-B weather data occurs automatically without any pilot action. FIS-B broadcasts provide weather data in a repeating cycle which may take approximately ten minutes to transmit all available weather data. Therefore, not all available weather data may be available immediately upon initial FIS-B signal acquisition.

Viewing the Weather Data Link (FIS-B) Page

- 1) Turn the large **FMS** Knob to select the Map Page Group.
- 2) Turn the small **FMS** Knob to select the Weather Data Link (FIS-B, XM, or CNXT) Page.
- 3) If the page title displays a weather data link weather source other than 'FIS-B', such as 'XM' or 'CNXT', proceed to the following steps to change the data link weather source.
- 4) Press the **MENU** Key.
- 5) Turn the small **FMS** Knob to select 'Display FIS-B Weather'.
- 6) Press the **ENT** Key. The page title will display 'MAP - WEATHER DATA LINK (FIS-B)' to indicate FIS-B is now the selected data link weather source.

Enabling/Disabling FIS-B Weather

- 1) Select the Weather Data Link (FIS-B) Page.
- 2) Press the **MENU** Key.
- 3) Turn the small **FMS** Knob to highlight 'Enable FIS-B Weather' or 'Disable FIS-B Weather', and press the **ENT** Key.

FIS-B Weather Product	Symbol	Expiration Time (Minutes)	Broadcast Rate (Minutes)
NEXRAD Composite (US)		30	15
NEXRAD Composite (Regional)		30	2.5
Meteorological Aerodrome Report (METARs)		90	5
Pilot Weather Report (PIREPs)		90	10
Winds Aloft (WIND)		90	10
SIGMETs/AIRMETs (SIG/AIR)		60	5
No Radar Coverage	no product image	30	2.5
Terminal Aerodrome Forecast	no product image	60	10
Temporary Flight Restriction (TFR)	no product image		10

Weather Product Symbols and Data Timing

Setting Up and Customizing the Weather Data Link (FIS-B) Page

- 1) Select the Weather Data Link (FIS-B) Page.
- 2) Press the **MENU** Key.
- 3) With 'Weather Setup' highlighted, press the **ENT** Key.

- 4) Turn the small **FMS** Knob to select 'Product Group 1', and press the **ENT** Key.
- 5) Turn the large **FMS** Knob or press the **ENT** Key to scroll through product selections.
- 6) Turn the small **FMS** Knob to scroll through options for each product (ON/OFF, range settings, etc.).
- 7) Press the **ENT** Key to select an option.
- 8) Press the **FMS** Knob or **CLR** Key to return to the Weather Data Link (FIS-B) Page with the changed settings.

Setting Up and Customizing FIS-B Weather on the Navigation Map Page

- 1) Select the Navigation Map Page.
- 2) Press the **MENU** Key.
- 3) With 'Map Setup' highlighted, press the **ENT** Key.
- 4) Turn the small **FMS** Knob to select the 'Weather' Group and press the **ENT** Key.
- 5) Turn the large **FMS** Knob or press the **ENT** Key to scroll through product selections.
- 6) Turn the small **FMS** Knob to scroll through options for each product (ON/OFF, range settings).
- 7) Press the **ENT** Key to select an option.
- 8) Press the **FMS** Knob or **CLR** Key to return to the Navigation Map Page with the changed settings.

Displaying/Removing the Weather Product Information Box on the PFD Inset Map

- 1) On the PFD, press the **INSET** Softkey.
- 2) Press the **WX LGND** Softkey.
- 3) To remove the weather product information box, press the **WX LGND** Softkey again.

Viewing Legends for Displayed Weather Products on the Weather Data Link (FIS-B) Page

- 1) Select the Weather Data Link (FIS-B) Page.
- 2) Press the **LEGEND** Softkey to display the legends for the displayed weather products.
Or:
 - a) Press the **MENU** Key.
 - b) Select 'Weather Legend' and press the **ENT** Key.
- 3) To remove the Legend Window, press the **LEGEND** Softkey, the **ENT** or the **CLR** Key, or press the **FMS** Knob.

Viewing Legends for Displayed Weather Products on the Navigation Map Page

- 1) Select the Navigation Map Page.
- 2) Press the **MAP** Softkey.
- 3) Press the **LEGEND** Softkey (available if one or more FIS-B weather products are enabled for display).
- 4) To remove the Legend Window, press the **LEGEND** Softkey, the **ENT** or the **CLR** Key, or press the **FMS** Knob.

Displaying NEXRAD Data

- 1) Press the **MAP** Softkey (for the PFD Inset Map, press the **INSET** Softkey). This step is not necessary on the Weather Data Link (FIS-B) Page.
- 2) Press the **NEXRAD-C** Softkey. This softkey becomes the **US** Softkey. A mosaic of NEXRAD data for the continental United States (CONUS) is displayed.
- 3) To display the regional version of the NEXRAD weather product, press the **US** Softkey. Softkey becomes the **RGNL** Softkey.
- 4) To remove the NEXRAD weather product, press the **RGNL** Softkey. Softkey becomes the **NEXRAD-C** Softkey.

Displaying SIGMETs and AIRMETs

- 1) Select the Weather Data Link (FIS-B) Page.
- 2) Press the **SIG/AIR** Softkey.

- 3) To view the text of the SIGMET or AIRMET, press the **Joystick** and move the Map Pointer over the icon.
- 4) Press the **ENT** key.

Displaying METAR and TAF Text

- 1) On the Weather Data Link (FIS-B) Page, press the **METAR** Softkey.
- 2) Press the **Joystick** and pan to the desired airport.
- 3) Press the **ENT** Key. The Weather Information Page is shown with METAR and TAF text.
- 4) Use the **FMS** Knob or the **ENT** Key to scroll through the METAR and TAF text. METAR text must be completely scrolled through before scrolling through the TAF text.
- 5) Press the **FMS** Knob or the **CLR** Key to return to the Weather Data Link (FIS-B) Page.

Or:

- 1) Select the Weather Information Page.
 - a) Turn the large **FMS** Knob to select the Waypoint Page Group.
 - b) Press the **WX** Softkey to select the Weather Information Page.
- 2) Press the **FMS** Knob to display the cursor.
- 3) Use the **FMS** Knob to enter the desired airport and press the **ENT** Key.
- 4) Use the **FMS** Knob or the **ENT** Key to scroll through the METAR and TAF text. Note that the METAR text must be completely scrolled through before scrolling through the TAF text.

Displaying Raw METAR Text on the Active Flight Plan Page

- 1) Select the Active Flight Plan Page on the MFD.
- 2) Press the **FMS** Knob to activate the cursor.
- 3) Turn the large **FMS** Knob to highlight the desired waypoint. The METAR text will appear in the 'SELECTED WAYPOINT WEATHER' window below.
- 4) When finished, press the **FMS** Knob to remove the cursor or press the **FPL** Key to exit the Active Flight Plan Page.

Displaying Winds Aloft Information

- 1) Select the Weather Data Link (FIS-B) Page.
- 2) Press the **MORE WX** Softkey.

- 3) Press the **WIND OFF** Softkey.
- 4) Press the softkey for the desired altitude. Press the **NEXT** or **PREV** Softkey to cycle through the altitude softkeys. The **WIND** Softkey label changes to reflect the altitude selected.

Enabling/Disabling Predicted Temperatures with Winds Aloft Data

- 1) Select the Weather Data Link (FIS-B) Page.
- 2) Press the **MENU** Key.
- 3) Turn the small **FMS** Knob to highlight 'Weather Setup' and press the **ENT** Key.
- 4) Turn the small **FMS** Knob to highlight 'PRODUCT GROUP 1' and press the **ENT** Key.
- 5) Turn the small **FMS** Knob to highlight the Temp (•) 'ON' or 'OFF' field, then press the **ENT** Key.
- 6) When finished, push the **FMS** Knob or the **CLR** Key.

Displaying PIREP Text

- 1) Select the Weather Data Link (FIS-B) Page.
- 2) Press the **MORE WX** Softkey.
- 3) Press the **PIREPS** Softkey.
- 4) Press the **Joystick** and pan to the desired weather report. A gray circle will appear around the weather report when it is selected.
- 5) Press the **ENT** Key. The PIREP text is first displayed in a decoded fashion, followed by the original text. Note the original text may contain additional information not shown in the decoded version.
- 6) Use the **FMS** Knob or the **ENT** Key to scroll through the PIREP text.
- 7) Press the **FMS** Knob or the **CLR** Key to close the PIREP text window and return to the Weather Data Link (FIS-B) Page.

Displaying TFR Data

- 1) Select the Weather Data Link (XM) Page or Navigation Map Page.
- 2) Press the **Joystick** and pan the map pointer over a TFR to highlight it. The system displays TFR summary information above the map.
- 3) Press the **ENT** Key. The system displays a pop-up menu.

- 4) If necessary, turn the **FMS** Knob to select 'Review Airspaces' and press the **ENT** Key. The system displays the INFORMATION window.
- 5) Press the **FMS** Knob or the **CLR** Key to remove the INFORMATION window.

Viewing FIS-B Weather Status

- 1) Turn the large **FMS** Knob to select the AUX Page Group.
- 2) Turn the small **FMS** Knob to select the AUX - ADS-B Status Page.













ADS-B Status Page Item	Status Message	Description
FIS-B Weather Status: FIS-B Processing	ENABLED	The FIS-B weather feature is enabled to process and display FIS-B weather products.
	DISABLED	The FIS-B weather feature is disabled.
	-----	No data received from the GDL 88 UAT.
Weather Products: AIRMET CONUS NEXRAD METAR METAR GRAPHICAL NOTAM/TFR PIREP REGIONAL NEXRAD SIGMET TAF WINDS/TEMPS ALOFT	AVAILABLE	FIS-B weather data is available for display for the weather product.
	NOT AVAILABLE	FIS-B weather data is not available for the weather product, and/or the system is not receiving the FIS-B weather service.
	AWAITING DATA	The system is receiving the FIS-B weather service, and is waiting to receive the weather product from the FIS-B data broadcast.

AUX-ADS-B Status Page Messages for FIS-B Weather

TRAFFIC ADVISORY SYSTEMS



WARNING: Traffic information shown on the Perspective Multi Function Display is provided as an aid in visually acquiring traffic. Pilots must maneuver the aircraft based only upon ATC guidance or positive visual acquisition of conflicting traffic.

Traffic Symbol	Description
	Traffic Advisory with directional information. Points in the direction of the intruder aircraft track. Available only with the GDL 88.
	Traffic Advisory with directional information. Points in the direction of the intruder aircraft track.
	Traffic Advisory without directional information.
	Traffic Advisory out of the selected display range. Displayed at outer range ring at proper bearing.
	Proximity Advisory with directional information. Points in the direction of the aircraft track.
	Proximity Advisory without directional information.
	Non-threat traffic with directional information. Points in the direction of the intruder aircraft track.
	Non-threat traffic without directional information.
	Traffic with ADS-B directional information, but positional accuracy is degraded. Points in the direction of the aircraft track.
	Traffic located on the ground with directional information. Points in the direction of the aircraft track. Ground traffic is only displayed when ADS-B is in Surface (SURF) Mode or own aircraft is on the ground. Available only with the GDL 88.
	Ground traffic without directional information. Ground traffic is only displayed when ADS-B is in Surface (SURF) Mode or own aircraft is on the ground. Available only with the GDL 88.
	Non-aircraft ground traffic. Ground traffic is only displayed when ADS-B is in Surface (SURF) Mode or own aircraft is on the ground. Available only with the GDL 88.

Traffic Symbol Description

Avidyne TAS610 Series Traffic Advisory System (Optional)

Displaying Traffic on the Traffic Map Page:

- 1) Turn the large **FMS** Knob to select the Map Page Group.
- 2) Turn the small **FMS** Knob to select the Traffic Map Page.
- 3) Turn the **Joystick** clockwise to display a larger area or counter-clockwise to display a smaller area.
- 4) Press the **MUTE** Softkey once to mute TAS voice alerts. Press twice rapidly to replay the last voice alert.

Displaying Traffic on the Navigation Map:

- 1) Ensure TAS is operating.
- 2) With the Navigation Map displayed, press the **MAP** Softkey.
- 3) Press the **TRAFFIC** Softkey. Traffic is now displayed on the map.

GTS 800 (Optional)

The optional Garmin GTS 800 is a Traffic Advisory System (TAS). This systems display traffic information for transponder-equipped aircraft. The system also provides visual annunciations and voice traffic alerts to assist the pilot in visually acquiring traffic.



NOTE: A 1090 MHz extended squitter transponder is required to display ADS-B symbology for aircraft providing ADS-B data.

System Self Test:

- 1) Set the range to 2/6 nm.
- 2) Press the **STANDBY** Softkey.
- 3) Press the **TEST** Softkey.
- 4) Self test takes approximately eight seconds to complete. When completed successfully, traffic symbols display and a voice alert "Traffic Advisory System Test Passed" is heard. If the self test fails, the system reverts to Standby Mode and a voice alert "Traffic Advisory System Test Failed" is heard.

Enabling/Disabling Flight ID Display:

On the Traffic Map Page, press the **FLT ID** Softkey.

Displaying Traffic on the Traffic Map Page:

- 1) Turn the large **FMS** Knob to select the Map Page Group.
- 2) Turn the small **FMS** Knob to select the Traffic Map Page.
- 3) Press the **OPERATE** Softkey to begin displaying traffic. OPERATING is displayed in the Traffic mode field.
- 4) Press the **ALT MODE** Softkey to change the altitude volume.
- 5) Press the **STANDBY** Softkey to place the system in the Standby mode. STANDBY is displayed in the Traffic mode field.
- 6) Turn the **Joystick** clockwise to display a larger area or counter-clockwise to display a smaller area.

Displaying Traffic on the Navigation Map:

- 1) Ensure TAS is operating.
- 2) With the Navigation Map displayed, press the **MAP** Softkey.
- 3) Press the **TRAFFIC** Softkey. Traffic is now displayed on the map.

L-3 Skywatch Traffic (Optional)

Switching from standby mode to operating mode:

- 1) On the Traffic Page, press the **OPERATE** Softkey or press the **MENU** Key and turn the small **FMS** knob to select Operating Mode.
- 2) If using the FMS menu, press the **ENT** Key to place the SKY497 in the operating mode.
- 3) To switch to Standby Mode from the Traffic Page, press the **STANDBY** Softkey.

Testing the Traffic Advisory System:

- 1) Set the range to 2/6 nm to allow for full traffic test pattern display.
- 2) Press the **STANDBY** Softkey.

- 3) Press the **TEST** Softkey.
- 4) System test takes approximately eight seconds to complete. When completed successfully, traffic symbols display and a voice alert "Traffic Advisory System Test Passed" is heard. If the system test fails, the system reverts to Standby Mode and a voice alert "Traffic Advisory System Test Failed" is heard.

Displaying traffic on the Traffic Map Page:

- 1) Turn the large **FMS** Knob to select the Map Page Group.
- 2) Turn the small **FMS** Knob to select the Traffic Map Page.
- 3) Press the **OPERATE** Softkey to begin displaying traffic. OPERATING is displayed in the Traffic mode field.
- 4) Press the **ALT MODE** Softkey to change the altitude volume.
- 5) Press the **STANDBY** Softkey to place the system in the Standby mode. STANDBY is displayed in the Traffic mode field.
- 6) Turn the **Joystick** clockwise to display a larger area or counter-clockwise to display a smaller area.

GDL 88 ADS-B Traffic (Optional)

The optional Garmin GDL 88 is a dual-link Universal Access Transceiver (UAT). It sends and receives Automatic Dependent Surveillance-Broadcast (ADS-B) traffic information on the 978 MHz UAT frequency. The system provides visual annunciations and voice traffic alerts to help the pilot visually acquire potentially conflicting traffic.

Enabling/Disabling the Display of ADS-B Traffic

- 1) Select the Traffic Map Page.
- 2) Press the **ADS-B** Softkey.

Testing ADS-B Traffic

- 1) Select the Traffic Map Page.
- 2) If necessary, turn the Joystick to select a map range of 2 and 6 nm to ensure full test pattern display.
- 3) Ensure the **ADS-B** Softkey is disabled.
- 4) If the optional TAS/TCAS I is installed, ensure the **TAS STBY** Softkey is enabled.
- 5) Press the **Test** Softkey.

Enabling/Disabling the Display of Flight IDs

- 1) Select the Traffic Map Page.
- 2) Press the **FLT ID** Softkey to enable/disable the display of Flight IDs.

Changing the Altitude Range

- 1) On the Traffic Map Page, select the **ALT MODE** Softkey.
- 2) Press one of the following Softkeys:
 - **ABOVE:** Displays non-threat and proximity traffic from 9000 feet above the aircraft to 2700 feet below the aircraft. Typically used during climb phase of flight.
 - **NORMAL:** Displays non-threat and proximity traffic from 2700 feet above the aircraft to 2700 feet below the aircraft. Typically used during enroute phase of flight.
 - **BELOW:** Displays non-threat and proximity traffic from 2700 feet above the aircraft to 9000 feet below the aircraft. Typically used during descent phase of flight.
 - **UNREST (unrestricted):** All traffic is displayed from 9900 feet above and 9900 feet below the aircraft.
- 3) To return to the Traffic Map Page, press the **BACK** Softkey.

Enabling/Disabling the Motion Vector Display

- 1) Select the Traffic Map Page.
- 2) Press the **MOTION** Softkey.
- 3) Press one of the following softkeys:
 - **ABS:** Displays the motion vector pointing in the absolute direction.
 - **REL:** Displays the motion vector relative to own aircraft
 - **OFF:** Disables the display of the motion vector.

Adjusting the Duration for the Motion Vector Projected Time

- 1) Select the Traffic Map Page.
- 2) Press the **MOTION** Softkey.
- 3) Press the **DURATION** Softkey.
- 4) Press a softkey for the desired duration (**30 SEC, 1 MIN, 2 MIN, 5 MIN**).
- 5) When finished, press the **BACK** Softkey to return to the Traffic Map Page.

Showing Additional Traffic Information

- 1) Select the Traffic Map Page.
- 2) Press the **FMS** Knob. A cyan bracket highlights the first selected traffic symbol. Additional information appears in a window in the upper-right corner of the Traffic Map Page.
- 3) To select a different aircraft symbol, turn the **FMS** Knob to move the cyan bracket until the selected aircraft traffic symbol is highlighted.
- 4) When finished, press the **FMS** Knob again to remove the cyan selection bracket.

Viewing ADS-B Traffic Status

- 1) Turn the large **FMS** Knob to select the AUX Page Group.
- 2) Turn the small **FMS** Knob to select the AUX - ADS-B Status Page.

ADS-B Status Page Item	Status Message	Description
Traffic Application Status: AIRBORNE (AIRB), SURFACE (SURF), AIRBORNE ALERTS (CSA)	ON	Traffic application is currently on. Required input data is available, and it meets performance requirements.
	AVAILABLE TO RUN	Traffic application is not currently active, but application is ready to run when condition(s) determine the application should be active. Required input data is available, and it meets performance requirements.
	NOT AVAILABLE	Traffic application is not available. Required input data is available, but it does not meet performance requirements.
	FAULT	Traffic application is not available. Required input data is not available or the application has failed.
	NOT CONFIGURED	Traffic application is not available, because it has not been configured. If this annunciation persists, the system should be serviced.
	-----	Traffic application status is invalid or unknown.

ADS-B Status Page Item	Status Message	Description
TIS-B/ADS-R Coverage	AVAILABLE	The system is receiving the ADS-R coverage from an FAA ground station.
	NOT AVAILABLE	The system is not receiving the ADS-R coverage from an FAA ground station.
	-----	ADS-R coverage is invalid or unknown.
GPS Status: GPS Source	External #1	The GDL 88 is using the #1 GPS receiver for the GPS position source.
	External #2	The GDL 88 is using the #2 GPS receiver for the GPS position source.
	-----	The GPS source is invalid or unknown.
Ground Uplink Status: Last uplink	Number of minutes, or '-----'	Displays the number of minutes since the last uplink from a ground station occurred. If no uplink has been received, or the status is invalid, dashes appear instead of a number of minutes.

AUX-ADS-B Status Page Messages for ADS-B Traffic

TERRAIN AND OBSTACLE PROXIMITY



NOTE: Terrain data is not displayed when the aircraft is outside the installed terrain database coverage area.

Displaying Terrain and Obstacles on the Terrain Proximity Page:

- 1) Turn the large **FMS** Knob to select the Map Page Group.
- 2) Turn the small **FMS** Knob to select the Terrain Proximity Page.
- 3) If desired, press the **VIEW** Softkey to access the **ARC** and **360** Softkeys. When the **ARC** Softkey is pressed, a radar-like 120° view is displayed. Press the **360** Softkey to return to the 360° default display.

- 4) Rotate the **Joystick** clockwise to display a larger area or rotate counter-clockwise to display a smaller area.

Color	Terrain/Obstacle Location
Red	Terrain/Obstacle above or within 100' below current aircraft altitude.
Yellow	Terrain/Obstacle between 100' and 1000' below current aircraft altitude.
Black	Terrain/Obstacle is more than 1000' below aircraft altitude.

Displaying Terrain and Obstacles on the Navigation Map:

- 1) With the Navigation Map displayed, press the **MAP** Softkey.
- 2) Press the **TERRAIN** Softkey. Terrain and obstacle proximity will now be displayed on the map.
- 3) Terrain and obstacles may be displayed in the Profile View by selecting the **PROFILE** Softkey.

TERRAIN-SVT (OPTIONAL)



NOTE: *Terrain-SVT is only available when the Synthetic Vision System (SVT) option is installed and the TAWS-B option has not been installed.*



NOTE: *Terrain data is not displayed when the aircraft is outside the installed terrain database coverage area.*

Display Terrain on the TERRAIN-SVT Page:

- 1) Turn the large **FMS** Knob to select the Map Page Group.
- 2) Turn the small **FMS** Knob to select the Terrain-SVT Page.
- 3) If desired, press the **VIEW** Softkey to access the **ARC** and **360** softkeys. When the **ARC** Softkey is selected, a radar-like 120° view is displayed. Press the **360** Softkey to return to the 360° default display.

- Flight Instruments
- EIS
- Nav/Com/XPDR/Audio
- AFCs
- GPS Nav
- Flight Planning
- Procedures
- Hazard Avoidance
- Additional Features
- Abnormal Operation
- Annun/Alerts
- Appendix
- Index

- 4) Rotate the **Joystick** clockwise to display a larger area or rotate counter-clockwise to display a smaller area.

Color	Terrain/Obstacle Location
Red	Terrain/Obstacle above or within 100' below current aircraft altitude.
Yellow	Terrain/Obstacle between 100' and 1000' below current aircraft altitude.
Black	Terrain/Obstacle is more than 1000' below aircraft altitude.

Enable/Disable Aviation Data:

- 1) While the Terrain-SVT Page is displayed, press the **MENU** Key.
- 2) Turn the small **FMS** Knob to select "Show (or Hide) Aviation Data".
- 3) Press the **ENT** Key.

Terrain-SVT Inhibit

Inhibit Terrain Alerting:

While the Terrain-SVT Page is displayed, press the **INHIBIT** Softkey.

Or:

- 1) Press the **MENU** Key.
- 2) Turn the small **FMS** Knob to select 'Inhibit Terrain'.
- 3) Press the **ENT** Key.

Enable Terrain Alerting:

While the Terrain-SVT Page is displayed, press the **INHIBIT** Softkey.

Or:

- 1) While the Terrain-SVT Page is displayed, press the **MENU** Key.
- 2) Turn the small **FMS** Knob to select 'Enable Terrain'.
- 3) Press the **ENT** Key.



NOTE: *If Terrain-SVT alerts are inhibited when the Final Approach Fix is the active waypoint in a GPS SBAS approach, a LOWALT annunciation may appear on the PFD next to the altimeter if the current aircraft altitude is at least 164 feet below the prescribed altitude at the Final Approach Fix.*

Displaying Terrain and Obstacles on the Navigation Map:

- 1) With the Navigation Map displayed, press the **MAP** Softkey.
- 2) Press the **TERRAIN** Softkey. Terrain and obstacle proximity will now be displayed on the map.
- 3) Terrain and obstacles may be displayed in the Profile View by selecting the **PROFILE** Softkey.

TERRAIN AWARENESS & WARNING SYSTEM (TAWS-B) DISPLAY (OPTIONAL)



WARNING: *The TAWS display shows supplemental information only. It should not be used for navigation.*



NOTE: *Terrain data is not displayed when the aircraft is outside the installed terrain database coverage area.*



NOTE: *TAWS operation is only available when the Perspective system is configured for a TAWS-B installation.*

Manual System Test:

- 1) While the TAWS-B Page is displayed, press the **MENU** Key.
- 2) Turn the small **FMS** Knob to select 'Test TAWS System'.
- 3) Press the **ENT** Key. During the test 'TAWS TEST' is displayed in the center of the TAWS-B Page.

When all is in working order, a single aural chime is heard.

Display Terrain on the TAWS-B Page:

- 1) Turn the large **FMS** Knob to select the Map Page Group.
- 2) Turn the small **FMS** Knob to select the TAWS-B Page.
- 3) If desired, press the **VIEW** Softkey to access the **ARC** and **360** softkeys. When the **ARC** Softkey is selected, a radar-like 120° view is displayed. Press the **360** Softkey to return to the 360° default display.
- 4) Rotate the **Joystick** clockwise to display a larger area or rotate counter-clockwise to display a smaller area.

Color	Terrain/Obstacle Location
Red	Terrain/Obstacle above or within 100' below current aircraft altitude.
Yellow	Terrain/Obstacle between 100' and 1000' below current aircraft altitude.
Black	Terrain/Obstacle is more than 1000' below aircraft altitude.

Enable/Disable Aviation Data:

- 1) While the TAWS-B Page is displayed, press the **MENU** Key.
- 2) Turn the small **FMS** Knob to select "Show (or Hide) Aviation Data".
- 3) Press the **ENT** Key.

TAWS Inhibit



NOTE: If TAWS alerts are inhibited when the Final Approach Fix is the active waypoint in a GPS SBAS approach, a LOW ALT annunciation may appear on the PFD next to the altimeter if the current aircraft altitude is at least 164 feet below the prescribed altitude at the Final Approach Fix.

Inhibit TAWS:

While the TAWS-B Page is displayed, press the **INHIBIT** Softkey.

Or:

- 1) Press the **MENU** Key.
- 2) Turn the small **FMS** Knob to select 'Inhibit TAWS'.
- 3) Press the **ENT** Key.

Enable TAWS:

While the TAWS-B Page is displayed, press the **INHIBIT** Softkey.

Or:

- 1) While the TAWS-B Page is displayed, press the **MENU** Key.
- 2) Turn the small **FMS** Knob to select 'Enable TAWS'.
- 3) Press the **ENT** Key.

Displaying Terrain and Obstacles on the Navigation Map:

- 1) With the Navigation Map displayed, press the **MAP** Softkey.
- 2) Press the **TERRAIN** Softkey. Terrain and obstacle proximity will now be displayed on the map.
- 3) Terrain and obstacles may be displayed in the Profile View by selecting the **PROFILE** Softkey.

ADDITIONAL FEATURES

SYNTHETIC VISION (OPTIONAL)



WARNING: Use appropriate primary systems for navigation, and for terrain, obstacle, and traffic avoidance. SVT is intended as an aid to situational awareness only and may not provide the accuracy and/or fidelity upon which to solely base decisions and/or plan maneuvers to avoid terrain, obstacles, or traffic.



WARNING: Do not use SVT runway depiction as the sole means for determining the proximity of the aircraft to the runway or for maintaining the proper approach path angle during landing.

Synthetic Vision Technology (SVT) functionality is offered as an optional enhancement to the Perspective Integrated Avionics System.

SVT is primarily comprised of a computer-generated forward-looking, attitude aligned view of the topography immediately in front of the aircraft from the pilot's perspective. SVT information is shown on the primary flight display (PFD).

In addition to SVT enhancement to the PFD, the following features have been added to the PFD:

- Pathways
- Flight Path Marker
- Horizon Heading Marks
- Terrain and Obstacle Alerting
- Three-dimensional Traffic
- Airport Signs
- Runway Display

Enabling/disabling SVT:

- 1) Press the **PFD** Softkey.
- 2) Press the **SYN VIS** Softkey.
- 3) Press the **SYN TERR** Softkey. The SVT display will cycle on or off with the **SYN TERR** Softkey.

Enabling/disabling Pathways:

- 1) Press the **PFD** Softkey.
- 2) Press the **SYN VIS** Softkey.
- 3) Press the **PATHWAY** Softkey. The Pathway feature will cycle on or off with the **PATHWAY** Softkey.

Enabling/disabling Horizon Heading:

- 1) Press the **PFD** Softkey.
- 2) Press the **SYN VIS** Softkey.
- 3) Press the **HRZN HDG** Softkey. The horizon heading display will cycle on or off with the **HRZN HDG** Softkey.

Enabling/disabling Airport Signs:

- 1) Press the **PFD** Softkey.
- 2) Press the **SYN VIS** Softkey.
- 3) Press the **APTSIGNS** Softkey. Display of airport signs will cycle on or off with the **APTSIGNS** Softkey.

Enabling/disabling the Flight Path Marker Independent of SVT:

- 1) Press the **PFD** Softkey.
- 2) Press the **SYN VIS** Softkey.
- 3) With the **SYN TERR** Softkey disabled, press the **HRZN HDG** Softkey.
- 2) Press the **FPM** Softkey.

ENHANCED VISION SYSTEM (OPTIONAL)

The Perspective system provides a control and display interface to an Enhanced Vision System. EVS is designed to provide an aid to situational awareness while operating in low visibility environments.

Accessing the EVS System:

- 1) Turn the large **FMS** Knob to select the AUX Page Group.
- 2) Turn the small **FMS** Knob to select the VIDEO Page.
- 3) Pressing the **VID ZM +** and **VID ZM -** softkeys switches the EVS display magnification between 1x and 2x.
- 4) Pressing the **HIDE MAP** Softkey removes the map from the display and increases the EVS display to full screen.

Adjusting the EVS Display:

- 1) Turn the large **FMS** Knob to select the AUX Page Group.
- 2) Turn the small **FMS** Knob to select the VIDEO Page.
- 3) Press the **SETUP** Softkey. The EVS display adjustment softkeys are now displayed.
- 4) Pressing the **CNTRST -** and **CNTRST +** Softkeys adjust display contrast in five percent increments from 0 to 100%.
- 5) Pressing the **BRIGHT -** and **BRIGHT +** Softkeys adjust display brightness in five percent increments from 0 to 100%.
- 6) Pressing the **SAT -** and **SAT +** Softkeys adjust display saturation in five percent increments from 0 to 100%.
- 7) Pressing the **RESET** Softkey returns all video adjustments options to the default settings
- 8) Press the **BACK** Softkey to return to the previous softkey level, or after 45 seconds of softkey inactivity, the system reverts to the top level AUX - VIDEO Page softkeys.

TERMINAL PROCEDURE CHARTS



NOTE: *With the availability of SafeTaxi®, ChartView, or FliteCharts®, it may be necessary to carry another source of charts on-board the aircraft.*

SafeTaxi®

SafeTaxi® is an enhanced feature that gives greater map detail as the map range is adjusted in on the airport. Resolution is greater at lower map ranges. The aircraft symbol provides situational awareness while taxiing.

Selecting the **DCLTR** Softkey cycles through the different declutter levels. **DCLTR** shows all map detail. **DCLTR-1** removes taxiway markings and airport identification labels. **DCLTR-2** removes VOR station ID, the VOR symbol, and intersection names if within the airport plan view. **DCLTR-3** removes the airport runway layout, unless the airport in view is part of an active flight plan.

The SafeTaxi database contains detailed airport diagrams for selected airports. These diagrams provide the pilot with situational awareness by displaying the aircraft position in relation to taxiways, ramps, runways, terminals, and services. This information should not be used by the pilot as the basis for maneuvering the aircraft on the ground. This database is updated on a 56-day cycle.

ChartView (Optional)

ChartView resembles the paper version of Jeppesen terminal procedures charts. The charts are displayed in full color with high-resolution. The MFD depiction shows the aircraft position on the moving map in the plan view of most approach charts and on airport diagrams.

The ChartView database is updated on a 14-day cycle. If the ChartView database is not updated within 70 days of the expiration date, ChartView will no longer function.

FliteCharts® (Optional)

FliteCharts® resemble the paper version of AeroNav Services terminal procedures charts. The charts are displayed with high-resolution and in color for applicable charts. The selected Display Pane depiction shows the aircraft position on the moving map in the plan view of most approach charts and on airport diagrams.

The FliteCharts database contains procedure charts for the United States only. This database is updated on a 28-day cycle. If not updated within 180 days of the expiration date, FliteCharts will no longer function.

View Charts from the Navigation Map Page:

- 1) Press the **SHW CHRT** Softkey when displayed.

Or:

Move the map pointer to point to a desired point on the map and press the **SHW CHRT** Softkey.

- 2) Select the **DP, STAR, APR, WX,** and **NOTAM** softkeys to access charts for departures, arrivals, approaches, weather and NOTAMS. Note that NOTAMS are only available with ChartView.
- 3) Press the **GO BACK** Softkey to return to the previous page.

View Charts from the Active Flight Plan Page:

- 1) While viewing the Active Flight Plan Page, press the **FMS** Knob to activate the cursor.
- 2) Turn the large **FMS** Knob to select the departure airport, destination airport, departure, arrival, or approach.
- 3) Press the **SHW CHRT** Softkey. The appropriate chart is displayed, if available for the item selected.
- 4) Press the **GO BACK** Softkey to return to the previous page.

Change Day/Night View:

- 1) While viewing a chart press the **MENU** Key to display the Page Menu OPTIONS.
- 2) Turn the large **FMS** Knob to highlight the 'Chart Setup' Menu Option and press the **ENT** Key.
- 3) Turn the large **FMS** Knob to move between the 'FULL SCREEN' and 'COLOR SCHEME' Options.
- 4) Turn the small **FMS** Knob to choose between the 'On' and 'Off' Full Screen Options.
- 5) Turn the small **FMS** Knob to choose between 'Day', 'Auto', and 'Night' Options.
- 6) In Auto Mode, turn the large **FMS** Knob to select the percentage field and change percentage with the small **FMS** Knob. The percentage of change is the day/night crossover point based on backlighting intensity.
- 7) Press the **FMS** Knob when finished to remove the Chart Setup Menu.

AIRPORT DIRECTORY

The AOPA or AC-U-KWIK Airport Directory adds enhanced airport information when viewing airports on the WPT-Airport Information Page.

The Airport Directory databases are revised every 56 days. Check fly.garmin.com for the current database.

View Airport Directory Information:

While viewing the WPT-Airport Information Page, if necessary, select the **INFO-1** Softkey to change the softkey label to display **INFO-2**. Airport Directory information is displayed on the right half of the display.

SIRIUSXM RADIO ENTERTAINMENT (OPTIONAL)

The SiriusXM Radio Page provides information and control of the audio entertainment features of the SiriusXM Satellite Radio.

Selecting the XM Radio Page:

- 1) Turn the large **FMS** Knob to select the Auxiliary Page Group.
- 2) Turn the small **FMS** Knob to select the XM Radio Page.
- 3) If necessary, press the **RADIO** Softkey to display the XM Radio Page where audio entertainment is controlled.

Active Channel and Channel List

The Active Channel Box on the XM Radio Page displays the currently selected channel. The Channels List Box of the XM Radio Page shows a list of the available channels for the selected category.

Selecting a Category:

The Category Box of the XM Radio Page displays the currently selected category of audio.

- 1) Press the **CATGRY** Softkey on the XM Radio Page.
- 2) Press the **CAT +** and **CAT -** softkeys to cycle through the categories.

Or:

Turn the small **FMS** Knob to display the 'Categories' list. Highlight the desired category with the small **FMS** Knob.

- 3) Press the **ENT** Key.

Select an Available Channel within the Selected Category:

- 1) While on the XM Radio Page, press the **CHNL** Softkey.
- 2) Press the **CH +** Softkey to go up through the list in the Channel Box, or move down the list with the **CH -** Softkey.

Or:

Press the **FMS** Knob to highlight the channel list and turn the large **FMS** Knob to scroll through the channels.

- 3) With the desired channel highlighted, press the **ENT** Key.

Entering a Channel Directly:

- 1) While on the XM Radio Page, press the **CHNL** Softkey.
- 2) Press the **DIR CH** Softkey. The channel number in the Active Channel Box is highlighted.
- 3) Press the numbered softkeys located on the bottom of the display to directly select the desired channel number. The number keys on the PFD/MFD Control Unit may also be used.
- 4) Press the **ENT** Key to activate the selected channel.

Assigning Channel Presets:

Up to 15 channels from any category can be assigned a preset number.

- 1) On the XM Radio Page, with the desired channel active, press the **PRESETS** Softkey to access the first five preset channels (**PS1 - PS5**).
- 2) Press the **MORE** Softkey to access the next five channels (**PS6 – PS10**), and again to access the last five channels (**PS11 – PS15**). Pressing the **MORE** Softkey repeatedly cycles through the preset channels.
- 3) Press any one of the (**PS1 - PS15**) softkeys to assign a number to the active channel.
- 4) Press the **SET** Softkey on the desired channel number to save the channel as a preset.

Adjusting Volume:

- 1) With the XM Radio Page displayed, press the **VOL** Softkey.
- 2) Press the **VOL –** Softkey to reduce volume or press the **VOL +** Softkey to increase volume. (Once the **VOL** Softkey is pressed, the volume can also be adjusted using the small **FMS** Knob.)

Mute SiriusXM Audio:

- 1) Select the XM Radio Page or XM Information Page.
- 2) Press the **MUTE** Softkey to mute the audio. Press the **MUTE** Softkey again to unmute the audio.

SATELLITE TELEPHONE & SMS MESSAGING SERVICE (OPTIONAL)

Operation of these features in the cockpit is accomplished through the AUX-TELEPHONE, and the AUX-TEXT MESSAGING SETUP Pages.

Registering With Garmin Connex

A subscriber account must be established prior to using the Iridium Satellite System. Before setting up an Iridium account, obtain the serial number of the Iridium Transceiver (GSRI) and the System ID by viewing the AUX- SYSTEM STATUS Page. Contact Garmin Connex at 1-866-739-5687 in the United States or (011) 913-440-1135.

Disable/Enable Iridium Transceiver

Iridium telephone may be turned on or off by performing the following steps.

To enable the Iridium telephone system:

- 1) With the AUX-TELEPHONE Page displayed, select the **MENU** Key on the MFD to display the Page Menu.
- 2) Turn either **FMS** Knob to place the cursor on 'Enable Iridium Transmission'.
- 3) Press the **ENT** Key.

To disable the Iridium telephone system:

- 1) With the AUX-TELEPHONE Page displayed, select the **MENU** Key on the MFD to display the Page Menu.
- 2) Turn either **FMS** Knob to place the cursor on 'Disable Iridium Transmission'.
- 3) Press the **ENT** Key.

Telephone Communication

The pilot or copilot can place and answer calls on the Iridium satellite network. Control and monitoring of telephone functions are accomplished through the AUX-TELEPHONE Page.

To view the Telephone Page:

- 1) Turn the large **FMS** Knob on the MFD to select the AUX page group.
- 2) Turn the small **FMS** Knob to select SATELLITE PHONE.

Internal Phone	External Phone	Description
		Phone is Idle
		Phone is ringing
		Phone has a dial tone (off hook) or connected to another phone
		Phone dialed is busy

Internal Phone	External Phone	Description
		Phone is dialing another phone
		Phone has failed
		Phone status not known
		Phone is disabled
		Phone is reserved for data transmission
		Calling other phone or incoming call from other phone
		Other phone is on hold
		Phones are connected

Contacts

The names, telephone number, and email addresses can be saved in a list of contacts for easy use when making telephone calls.

Entering a new contact:

- 1) With the AUX-TELEPHONE Page displayed, press the **FMS** Knob to display the cursor.
- 2) If necessary, turn either **FMS** Knob to place the cursor on 'NEW ENTRY'.
- 3) Press the **ENT** Key. The cursor moves the 'NAME' field of the 'CONTACT DETAILS' window.

- 4) Enter the desired name of the new contact. Entry can be accomplished through the alphanumeric keys on the MFD Controller, or the **FMS** Knobs on the controller or the MFD.
- 5) Press the **ENT** Key. The cursor moves to the 'PHONE NUMBER' field.
- 6) Enter the desired telephone number. Entry can be accomplished through the alphanumeric keys on the MFD Controller, or the **FMS** Knobs on the controller or the MFD.
- 7) Press the **ENT** Key. The cursor moves to the 'EMAIL' field.
- 8) Enter the desired email address. Entry can be accomplished through the alphanumeric keys on the MFD Controller, or the **FMS** Knobs on the controller or the MFD.
- 9) Press the **ENT** Key. The **SAVE** button is highlighted.
- 9) Press the **ENT** Key. The new contact entry is added to the list of saved contacts.

Delete a contact:

- 1) With the AUX-TELEPHONE Page displayed, press the **FMS** Knob to display the cursor.
- 2) Turn either **FMS** Knob to place the cursor on the desired contact name.
- 3) Select the **DELETE** Softkey. A confirmation window is displayed.
- 4) With 'OK' highlighted, press the **ENT** Key to delete the selected contact.

Edit a contact:

- 1) With the AUX-TELEPHONE Page displayed, press the **FMS** Knob to display the cursor.
- 2) Turn either **FMS** Knob to place the cursor on the desired contact name.
- 3) Select the **EDIT** Softkey. The cursor is placed in the 'NAME' field. Enter the desired changes. Entry can be accomplished through the alphanumeric keys on the MFD Controller, or the **FMS** Knobs on the controller or the MFD.
- 4) Press the **ENT** Key when each field is complete. The **SAVE** Button is now highlighted.
- 5) Press the **ENT** Key to save the changes.

Incoming Calls

When viewing MFD pages other than the AUX-TELEPHONE Page, a pop-up alert will be displayed. The pop-up alert may be inhibited at times, such as during takeoff. In addition to the pop-up alert, a ringing phone symbol will be displayed to the right of the MFD page title. Also, the voice alert “Incoming Call” will be heard on the selected cockpit audio.



NOTE: The Push-to-Talk switch is not utilized for telephone communication. The microphone is active after selecting the **ANSWER** Softkey, and stays active until the call is terminated.

Answering an incoming call:

- 1) Press the  Key (GMA 350/350c) or **TEL** Key (GMA 347) on the audio panel.
- 2) Select the **ANSWER** Softkey on the MFD.

Or:

While viewing the AUX-TELEPHONE Page:

- 1) Press the  Key (GMA 350/350c) or **TEL** Key (GMA 347) on the audio panel.
- 2) Press the **MENU** Key to display the Page Menu.
- 3) Turn either **FMS** Knob to place the cursor on ‘Answer Incoming Call’.
- 4) Press the **ENT** Key.

Selecting the **IGNORE** Softkey will extinguish the pop-up window and leave the current call unanswered. Selecting the **IGNRE ALL** Softkey will extinguish the pop-up window for the current and all future incoming calls and leave the current call unanswered. Selecting the **TEL** Softkey will display the AUX-TELEPHONE Page allowing additional call information to be viewed before answering.

Disabling incoming call alerts:

- 1) With the AUX-TELEPHONE Page displayed, press the **MENU** Key on the MFD to display the Page Menu.
- 2) Turn either **FMS** Knob to place the cursor on ‘Disable Incoming Call Alerts’.
- 3) Press the **ENT** Key. The voice and pop-up alert will not be displayed now when an incoming call is received.

Outgoing Calls

Voice calls can be made from the cockpit through the Iridium Satellite Network.

To make a call:

- 1) Press the  Key (GMA 350/350c) or **TEL** Key (GMA 347) on the audio panel.
- 2) Select the **DIAL** Softkey on the MFD.

Or:

While viewing the AUX-TELEPHONE Page:

- a) Press the  Key (GMA 350/350c) or **TEL** Key (GMA 347) on the audio panel.
 - b) Press the **MENU** Key to display the Page Menu.
 - c) Turn either **FMS** Knob to place the cursor on 'Dial a Phone Call'.
 - d) Press the **ENT** Key.
- 3) Enter the desired number string (typically, country code + area code + phone number) by selecting the number softkeys on the MFD, pressing the numeric keys on the PFD/MFD Controller, or turning the FMS Knobs. The GSR 56 may be configured by an authorized repair facility to automatically enter a default country code when the dialing window is displayed. To replace the default country code, move the cursor to the first (furthest left) number in the dialing window and enter the desired country code.
 - 4) Press the **ENT** Key. 'OK' is highlighted.
 - 5) Press the **ENT** Key. The system will begin calling the number.

When the phone is answered, the connection is established. To exit the call, select the **HANGUP** Softkey.







Text Messaging (SMS)

Messages may be sent to an email address or text message capable cellular telephone. Message length is limited to 160 characters, including the email address.

The text messaging user interface is mainly through the AUX-TEXT MESSAGING Page.

Viewing the Text Messaging Page:

- 1) Turn the large **FMS** Knob on the MFD to select the AUX page group.
- 2) Turn the small **FMS** Knob to select SATELLITE PHONE.
- 3) If necessary, press the **SMS** Softkey to display the AUX-TEXT MESSAGING Page.

Message Symbol	Description
	Received text message that has not been opened
	Received text message that has been opened
	Saved text message, draft not sent
	System is sending text message
	Text message has been sent
	System failed to send text message
	Predefined text message

Viewing a Text Message When Received

When viewing MFD pages other than the AUX-TEXT MESSAGING Page, a pop-up alert will be displayed when a new text message is received.

Press the **VIEW** Softkey to view the message. Pressing the **IGNORE** Softkey will extinguish the pop-up window and leave the text message unopened. Pressing the **IGNR ALL** Softkey will extinguish the pop-window and ignore all future incoming text messages. Pressing the **SMS** Softkey will display the AUX-TEXT MESSAGING Page.

The pop-up alerts may be enabled or disabled through the Page Menu.

Enable/Disable Incoming Text Message Pop-Up Alerts:

- 1) With the AUX-TEXT MESSAGING Page displayed, press the **MENU** Key on the MFD to display the Page Menu.
- 2) Turn either **FMS** Knob to place the cursor on 'Disable New Message Popups' or 'Enable New Message Popups'.
- 3) Press the **ENT** Key. The pop-up alert will not be displayed when an incoming text message is received.

Reply to a Text Message:

While viewing the text message, press the **REPLY** Softkey.

Or:

- a) Press the **MENU** Key to display the Page Menu.
- b) Turn either **FMS** Knob to place the cursor on 'Reply To Message'.
- c) Press the **ENT** Key.

Sending a Text Message:

- 1) While viewing the AUX-TEXT MESSAGING Page, press the **NEW** Softkey.

Or:

- a) Press the **MENU** Key to display the Page Menu.
 - b) Turn either **FMS** Knob to place the cursor on 'Draft New Message'.
 - c) Press the **ENT** Key.
- 2) The TEXT MESSAGE DRAFT Window is now displayed with the cursor in the 'TO' field. Enter the desired telephone number or email address. Entry can be accomplished through the alphanumeric keys on the PFD/MFD Control Unit, or combination of the **FMS** Knob on the controller and softkeys on the MFD. The **FMS** Knob is used to enter letters and numbers, or numbers can be entered from the MFD by pressing the **NUMBERS** Softkey. Press the **CAP LOCK** Softkey to create upper and lower case alpha characters. Special characters can be accessed by pressing the **SYMBOLS** Softkey.
 - 3) Press the **ENT** Key. The cursor is now displayed in the 'MESSAGE' field.
 - 4) Enter the desired message using any combination of entry methods as described in step 2.
 - 5) Press the **ENT** Key.
 - 6) Press the **SEND** Softkey to send the message immediately, or press the **SAVE** Softkey to save the message in Outbox for sending at a later time. Press the **CANCEL** Softkey to delete the message.

Predefined Text Messages

Time and effort can be saved in typing text messages that are used repeatedly by saving these messages as a predefined message.

Create a Predefined Text Message:

- 1) While viewing the AUX-TEXT MESSAGING Page, press the **MENU** Key to display the Page Menu.
- 2) Turn either **FMS** Knob to select 'Edit Predefined Messages'.
- 3) Press the **ENT** Key. The PREDEFINED MESSAGES view is now displayed.
- 4) Press the **NEW** Softkey.

Or:

 - a) Press the **MENU** Key to display the Page Menu.
 - b) Turn either **FMS** Knob to place the cursor on 'Draft New Predefined Message'.
 - c) Press the **ENT** Key. The PREDEFINED SMS TEXT MESSAGE Window is now displayed.
- 5) The cursor is displayed in the 'TITLE' field. Enter the desired message title. Entry can be accomplished through the alphanumeric keys on the PFD/MFD Control Unit, or combination of the **FMS** Knob on the controller and softkeys on the MFD. The **FMS** Knob is used to enter letters and numbers, or numbers can be entered from the MFD by pressing the **NUMBERS** Softkey. Press the **CAP LOCK** Softkey to create upper and lower case alpha characters. Special characters can be accessed by pressing the **SYMBOLS** Softkey.
- 6) Press the **ENT** Key. The cursor is now displayed in the 'MESSAGE' field.
- 7) Enter the desired message using any combination of entry methods as described in step 5.
- 8) Press the **ENT** Key.
- 9) Press the **SAVE** Softkey. The new predefined message is now shown in the displayed list. Pressing the **CANCEL** Softkey will delete the message without saving.
- 10) Press the **MENU** Key to display the Page Menu.
- 11) Turn either **FMS** Knob to place the cursor on 'Stop Editing Predefined Message'.
- 12) Press the **ENT** Key.

Send a Predefined Text Message:

- 1) While viewing the AUX-TEXT MESSAGING Page, press the **NEW** Softkey.
- 2) The TEXT MESSAGE DRAFT Window is now displayed with the cursor in the 'TO' field. Enter the desired telephone number or email address. Entry can be accomplished through the alphanumeric keys on the PFD/MFD Control Unit, or combination of the **FMS** Knob on the controller and softkeys on the MFD. The **FMS** Knob is used to enter letters and numbers, or numbers can be entered from the MFD by pressing the **NUMBERS** Softkey. Press the **CAP LOCK** Softkey to create upper and lower case alpha characters. Special characters can be accessed by pressing the **SYMBOLS** Softkey.
- 3) Press the **ENT** Key. The cursor is now displayed in the 'MESSAGE' field.
- 4) Press the **PREDEFD** Softkey. The PREDEFINED MESSAGE MENU Window is displayed.
- 6) Press the **ENT** Key. The predefined message text is inserted into the message field. If desired, the message can be edited by using the FMS Knobs.
- 7) Press the **ENT** Key.
- 8) Press the **SEND** Softkey to transmit the message.

Text Message Boxes

Received text messages reside in the Inbox as 'Read' or 'Unread' messages. The Outbox contains 'Sent' and 'Unsent' text messages. Saved messages that are meant to be sent later are stored as Drafts. Each text message box may be viewed separately, or together in any combination.

Show Inbox Messages:

While viewing the AUX-TEXT MESSAGING Page, press the **ARRANGE** Softkey, then press the **INBOX** Softkey.

Or:

- a) Press the **MENU** Key to display the Page Menu.
- b) Turn either **FMS** Knob to place the cursor on 'Show Inbox Messages'.
- c) Press the **ENT** Key. The message box selected for viewing is indicated at the bottom left of the list window.

Show Outbox Messages:

While viewing the AUX-TEXT MESSAGING Page, press the **ARRANGE** Softkey, then press the **OUTBOX** Softkey.

Or:

- a) Press the **MENU** Key to display the Page Menu.
- b) Turn either **FMS** Knob to place the cursor on 'Show Outbox Messages'.
- c) Press the **ENT** Key. The message box selected for viewing is indicated at the bottom left of the list window.

Show Draft Messages:

While viewing the AUX-TEXT MESSAGING Page, press the **ARRANGE** Softkey, then press the **DRAFTS** Softkey.

Or:

- a) Press the **MENU** Key to display the Page Menu.
- b) Turn either **FMS** Knob to place the cursor on 'Show Draft Messages'.
- c) Press the **ENT** Key. The message box selected for viewing is indicated at the bottom left of the list window.

Arranging Text Messages

The viewed messages may be listed according to the date/time the message was sent or received, the type of message (read, unread, sent, unsent, etc.), or by message address.

View Messages Sorted by Message Date/Time:

While viewing the AUX-TEXT MESSAGING Page, press the **ARRANGE** Softkey, then press the **TIME** Softkey.

Or:

- a) Press the **MENU** Key to display the Page Menu.
- b) Turn either **FMS** Knob to place the cursor on 'Sort By Date/Time'.
- c) Press the **ENT** Key. The sorting selection is indicated at the bottom center of the list window.

View Messages Sorted by Message Type:

While viewing the AUX-TEXT MESSAGING Page, press the **ARRANGE** Softkey, then press the **TYPE** Softkey.

Or:

- a) Press the **MENU** Key to display the Page Menu.
- b) Turn either **FMS** Knob to place the cursor on 'Sort By Type'.
- c) Press the **ENT** Key. The sorting selection is indicated at the bottom center of the list window.

View Messages Sorted by Address:

While viewing the AUX-TEXT MESSAGING Page, press the **ARRANGE** Softkey, then press the **ADDRESS** Softkey.

Or:

- a) Press the **MENU** Key to display the Page Menu.
- b) Turn either **FMS** Knob to place the cursor on 'Sort By Address'.
- c) Press the **ENT** Key. The sorting selection is indicated at the bottom center of the list window.

Viewing The Content of a Text Message

- 1) While viewing the AUX-TEXT MESSAGING Page, select the desired message box.
- 2) Press the **FMS** Knob to activate the cursor.
- 3) Turn either **FMS** Knob to select the desired message.
- 4) Press the **VIEW** Softkey.

Or:

Press the **ENT** Key.

Or:

- a) Press the **MENU** Key to display the Page Menu.
 - b) Turn either **FMS** Knob to place the cursor on 'View Selected Message'.
 - c) Press the **ENT** Key.
- 5) To close the text message, press the **CLOSE** Softkey.

Or:

- a) Press the **MENU** Key to display the Page Menu.
- b) Turn either **FMS** Knob to place the cursor on 'Close Message'.
- c) Press the **ENT** Key.

Mark Selected Message As Read:

- 1) While viewing the Inbox on the AUX-TEXT MESSAGING Page, press the **FMS** Knob to activate the cursor.
- 2) Turn either **FMS** Knob to select the desired message.
- 3) Press the **MRK READ** Softkey.

Or:

- a) Press the **MENU** Key to display the Page Menu.
- b) Turn either **FMS** Knob to place the cursor on 'Mark Selected Message As Read'.
- c) Press the **ENT** Key.

The message symbol now indicates the message has been opened.

Mark All Messages As Read

- 1) While viewing the Inbox on the AUX-TEXT MESSAGING Page, press the **MENU** Key to display the Page Menu.
- 2) Turn either **FMS** Knob to place the cursor on 'Mark All New Messages As Read'.
- 3) Press the **ENT** Key. A confirmation window is displayed.
- 4) With cursor highlighting 'YES', press the **ENT** Key. The message symbols now indicate all the message have been opened.

Delete a Message:

- 1) While viewing the Inbox on the AUX-TEXT MESSAGING Page, press the **FMS** Knob to activate the cursor.
 - 2) Turn either **FMS** Knob to select the desired message.
 - 3) Press the **DELETE** Softkey.
- Or:**
- a) Press the **MENU** Key to display the Page Menu.
 - b) Turn either **FMS** Knob to place the cursor on 'Delete Selected Message'.
 - c) Press the **ENT** Key.

WI-FI CONNECTIONS (OPTIONAL)

Control and monitoring of Wi-Fi functions are accomplished through the AUX-WI-FI SETUP Page.

Viewing the Wi-Fi Setup Page:

- 1) Turn the large **FMS** Knob on the MFD to select the AUX page group.
- 2) Turn the small **FMS** Knob to select REPORTS/DATA LINK.
- 3) If necessary, select the **WI-FI** Softkey to display the AUX-WI-FI SETUP Page.

Setting Up a New Wi-Fi Connection:

- 1) Select the **AVAIL** Softkey on the MFD. A list of available networks will be displayed in the AVAILABLE NETWORKS window. Signal strength is shown for each network, as well as security methods and whether the network has been saved in the system's memory.
- 2) If necessary, select the **RESCAN** Softkey to have the system scan again for available networks.
- 3) Press the **FMS** Knob to place the cursor in the list of networks.
- 4) Turn either **FMS** Knob to select the desired network.
- 5) Select the **CONNECT** Softkey.
- 6) If the network is secured, enter the necessary passcode. Use the **FMS** Knobs to enter the desired alpha numeric characters. Select the **CAP LOCK** Softkey to enter upper case letters. If there is no security associated with the network, proceed to step 9.
- 7) Press the **ENT** Key. 'OK' will be highlighted.
- 8) Press the **ENT** Key again.
- 9) The SAVE SETTINGS window is now displayed with the cursor highlighting 'SAVE CONNECTION'.
- 10) The selected network can be saved to system memory to make reconnection easier at a later time.

To connect the selected network without saving:

- a) Turn the large FMS Knob to move the cursor to highlight 'CONNECT'.
- b) Press the **ENT** Key.

To save and connect the selected network:

- a) Press the **ENT** Key. A checkmark is placed in the checkbox and the cursor moves to the airport field.
- b) Using the **FMS** Knobs, enter an airport identifier to be associated with the saved network. This aids in identifying the network later in the event of duplicate network names.
- c) Press the **ENT** Key. The cursor moves to 'CONNECT'.
- d) Press the **ENT** Key again to connect to the selected network.

Editing a Saved Network:

- 1) While viewing list of saved networks, press the **FMS** Knob to activate the cursor.
- 2) Turn either **FMS** Knob to highlight the network to be edited.
- 3) Pressing the **ENT** Key at this point will check or uncheck the AUTO CONNECT checkbox. When a checkmark is present, the system will automatically connect to the network when within range.
- 4) Select the **EDIT** Softkey. The cursor now appears in the CONNECTION SETTINGS window.
- 5) Turn the large **FMS** Knob to select the network attribute to be edited.
- 6) Turn the small **FMS** Knob to begin editing the field.
- 7) When the entry is complete, press the **ENT** Key.
- 8) Turn the large **FMS** Knob or press the **ENT** Key until 'SAVE' is highlighted.
- 9) Press the **ENT** Key.

Disconnecting a Wi-Fi Network:

Select the **DISCNCT** Softkey.

Deleting a Saved Wi-Fi Network:

- 1) While viewing the list of saved networks, press the **FMS** Knob to activate the cursor.
- 2) Turn either **FMS** Knob to highlight the network to be deleted.
- 3) Select the **DELETE** Softkey. The selected network is removed from the list.

SCHEDULER

The Scheduler feature can be used to enter and display reminder messages (e.g., Change oil, Switch fuel tanks, or Altimeter-Transponder Check) in the Messages Window on the PFD. Messages can be set to display based on a specific date and time (event), once the message timer reaches zero (one-time; default setting), or recurrently whenever the message timer reaches zero (periodic). Message timers set to periodic alerting automatically reset to the original timer value once the message is displayed. When power is cycled, all messages are retained until deleted, and message timer countdown is resumed.

Entering a scheduler message:

- 1) Select the AUX - Utility Page.
- 2) Press the **FMS** Knob momentarily to activate the flashing cursor.
- 3) Turn the large **FMS** Knob to highlight the first empty scheduler message naming field.
- 4) Use the **FMS** Knob to enter the message text to be displayed in the Messages Window and press the **ENT** Key.
- 5) Press the **ENT** Key again or use the large **FMS** Knob to move the cursor to the field next to Type.
- 6) Turn the small **FMS** Knob to select the message alert type:
 - Event—Message issued at the specified date/time
 - One-time—Message issued when the message timer reaches zero (default setting)
 - Periodic—Message issued each time the message timer reaches zero
- 7) Press the **ENT** Key again or use the large **FMS** Knob to move the cursor to the next field.
- 8) For periodic and one-time message, use the **FMS** Knob to enter the timer value (HH:MM:SS) from which to countdown and press the **ENT** Key.

- 9) For event-based messages:
 - a) Use the **FMS** Knob to enter the desired date (DD-MM-YY) and press the **ENT** Key.
 - b) Press the **ENT** Key again or use the large **FMS** Knob to move the cursor to the next field.
 - c) Use the **FMS** Knob to enter the desired time (HH:MM) and press the **ENT** Key.
- 10) Press the **ENT** Key again or use the large **FMS** Knob to move the cursor to enter the next message.

Deleting a scheduler message:

- 1) Select the AUX - Utility Page.
- 2) Press the **FMS** Knob momentarily to activate the flashing cursor.
- 3) Turn the large **FMS** Knob to highlight the name field of the scheduler message to be deleted.
- 4) Press the **CLR** Key to clear the message text. If the **CLR** Key is pressed again, the message is restored.
- 5) Press the **ENT** Key while the message line is cleared to clear the message time.

Scheduler messages appear in the Messages Window on the PFD. When a scheduler message is waiting, the **ALERTS** Softkey label changes to ADVISORY. Pressing the **ADVISORY** Softkey opens the Messages Window and acknowledges the scheduler message. The softkey label reverts to ALERTS when pressed. Pressing the **ALERTS** Softkey again removes the Messages Window from the display, and the scheduler message is deleted from the message queue.

ELECTRONIC CHECKLISTS (OPTIONAL)

The system accesses the checklists from an SD card inserted into the bezel slot. If the SD card contains an invalid checklist file or no checklist, the Power-up Page messages display 'Checklist File: Invalid' or 'Checklist File: N/A' (not available) and the **CHKLIST** Softkey is not available.

Accessing and Navigating Checklists:

- 1) From any page on the MFD (except EIS Pages), press the **CHKLIST** Softkey.
- 2) Turn the large **FMS** Knob to select the 'GROUP' field.

- 3) Turn the small **FMS** Knob to select the desired procedure and press the **ENT** Key.
- 4) Turn the large **FMS** Knob to select the 'CHECKLIST' field.
- 5) Turn the **FMS** Knob to select the desired checklist and press the **ENT** Key. The selected checklist item is indicated with white text surrounded by a white box.
- 6) Press the **ENT** Key or **CHECK** Softkey to check the selected checklist item. The line item turns green and a checkmark is placed in the associated box. The next line item is automatically selected for checking.
Either **FMS** Knob can be used to scroll through the checklist and select the desired checklist item.
Press the **CLR** Key or **UNCHECK** Softkey to remove a check mark from an item.
- 7) When all checklist items have been checked, '*Checklist Finished*' is displayed in green text at the bottom left of the checklist window. If all items in the checklist have not been checked, '*CHECKLIST NOT FINISHED*' will be displayed in yellow text.
- 8) Press the **ENT** Key. 'GO TO NEXT CHECKLIST?' will be highlighted by the cursor.
- 9) Press the **ENT** Key to advance to the next checklist.
- 10) Press the **EXIT** Softkey to exit the Checklist Page and return to the page last viewed.

Immediately Accessing Emergency Procedures:

- 1) From any page on the MFD, press the **CHKLIST** Softkey.
- 2) Press the **EMERGENCY** Softkey.
- 3) Turn the **FMS** Knob to select the desired emergency checklist and press the **ENT** Key.
- 4) Press the **ENT** Key or **CHECK** Softkey to check the selected emergency checklist item. The line item turns green and a checkmark is placed in the box next to it. The next line item is automatically highlighted for checking.
Either **FMS** Knob can be used to scroll through the checklist and select the desired checklist item.
Press the **CLR** Key or **UNCHECK** Softkey to remove a check mark from an item.

- 5) When all checklist items have been checked, '*Checklist Finished*' is displayed in green text at the bottom left of the checklist window. If all items in the checklist have not been checked, '*CHECKLIST NOT FINISHED*' will be displayed in yellow text.
- 6) Press the **ENT** Key. 'GO TO NEXT CHECKLIST?' will be highlighted by the cursor.
- 7) Press the **ENT** Key to advance to the next checklist.
- 8) Press the **RETURN** Softkey to return to the previous checklist.
- 9) Press the **EXIT** Softkey to exit the Checklist Page and return to the page last viewed.

HYPOXIA RECOGNITION WITH AUTOMATIC DESCENT MODE



NOTE: *The Automatic Descent Mode does not account for terrain elevation.*

The system is operative when the aircraft altitude is above 14,900 feet (pressure altitude) and the Garmin AFCS autopilot is engaged. Pilot interaction with the Perspective system is monitored by detecting key presses and turns of the knobs (Audio Panel and push-to-talk switch excluded). If a period of inactivity (time dependent on altitude) is detected, Hypoxia Recognition initiates and automatic descent.

When the system detects a sufficient period of inactivity the Advisory Annunciation 'ARE YOU ALERT?' is displayed. Selecting the **ALERT** Softkey will acknowledge the message and reset the system. Pressing any other softkey, or turning a knob will also reset the system.

When no pilot interaction is detected for an additional 60 seconds, the Caution Annunciation 'HYPOXIA ALERT' is displayed. Again, selecting the **ALERT** Softkey will acknowledge the message and reset the system. Pressing any other softkey, or turning a knob will also reset the system.

When no pilot interaction is detected for an additional 60 seconds, the Warning Annunciation 'AUTO DESCENT' is displayed in the Annunciation Window and 'Automatic descent to 14,000FT in 60 seconds' is displayed in the Alerts Window. Once again, selecting the **ALERT** Softkey will acknowledge the message and reset the system. Pressing any other softkey, or turning a knob will also reset the system.

When no interaction is detected for another 60 seconds, the system will automatically proceed with the descent.

As the system prepares for descent, the Selected Altitude is set to 14,000 and the AFCS enters Indicated Airspeed (IAS) mode with the airspeed reference set to the maximum allowable airspeed setting for the specific aircraft model. Refer to the Flight Director Vertical Modes in the AFCS section. AFCS lateral mode settings are not affected.

As the descent begins, an 'AUTO DESCENT' warning is displayed in the Annunciation Window. 'AUTO DESCENT - Aircraft Descending to 14,000FT' is displayed in the Alerts Window. 'EDM' is shown as an AFCS Status Annunciation indicating the system has entered Automatic Descent Mode. 'EDM' (Emergency Descent Mode) is the AFCS mode that is activated when Hypoxia Recognition initiates an automatic descent. A continuous repeating chime will be heard as long as Automatic Descent Mode is active. After the descent begins, Automatic Descent Mode can only be canceled by disconnecting the autopilot.

As the aircraft reaches 14,000 feet the system sets the AFCS to Altitude Hold mode. The AFCS will also remain in Automatic Descent Mode as indicated by 'EDM' continuing to be displayed as an AFCS Status Annunciation. The system again begins monitoring for pilot interaction.

If no pilot interaction is detected for four minutes, the system initiates the second descent. As the system prepares for this descent, the Selected Altitude is set to 12,500 and the AFCS again enters IAS mode with the airspeed reference set to the maximum allowable airspeed for the specific aircraft model.

As the descent begins, an 'AUTO DESCENT' warning is displayed in the Annunciation Window. 'AUTO DESCENT - Aircraft Descending to 12,500FT' is displayed in the Alerts Window. 'EDM' is shown as an AFCS Status Annunciation. Also, the continuous repeating chime is heard.

As the aircraft reaches 12,500 feet the system sets the AFCS to Altitude Hold mode. The AFCS will also remain in Automatic Descent Mode as indicated by 'EDM' continuing to be displayed as an AFCS Status Annunciation as well as the continuing presence of the repeating chime. At this point, the AFCS must be disconnected to cancel Automatic Descent Mode.

ELECTRONIC STABILITY AND PROTECTION (ESP™) (OPTIONAL)

The pilot can interrupt ESP by pressing and holding the Autopilot Disconnect (**AP DISC**) switch. Upon releasing the **AP DISC** switch, ESP force will again be applied, provided aircraft roll attitude is within engagement limits. ESP can also be overridden by overpowering the servo's mechanical torque limit.

ESP can be enabled or disabled on the AUX-SYSTEM SETUP 2 Page on the MFD.

To enable or disable ESP:

- 1) Turn the large **FMS** Knob to select the AUX Page Group.
- 2) Turn the small **FMS** Knob to select the System Setup Page.
- 3) If necessary, select the **SETUP 2** Softkey to display the AUX-SYSTEM SETUP 2 Page. If the AUX-SYSTEM SETUP 2 is already displayed, proceed to step 4.
- 4) Press the **FMS** Knob to activate the cursor.
- 5) Turn the large **FMS** Knob to place the cursor in the STABILITY & PROTECTION field.
- 6) Turn the small **FMS** Knob to select 'ENABLE' or 'DISABLE'.
- 7) Press the **FMS** Knob to remove the cursor.

ESP is automatically enabled on system power up.

Roll Engagement

Roll Limit Indicators are displayed on the roll scale at 45° right and left, indicating where ESP will engage. As roll attitude exceeds 45°, ESP will engage and the on-side Roll Limit Indicator will move to 30°. The Roll Limit Indicator is now showing where ESP will disengage as roll attitude decreases to within the desirable roll attitude range.

Once engaged, ESP force will be applied between 30° and 75°. The force increases as roll attitude increases and decreases as roll attitude decreases. The applied force is intended to encourage pilot input that returns the airplane to a more normal roll attitude. As roll attitude decreases, ESP will disengage at 30°.

ESP is automatically disengaged if the aircraft reaches the autopilot roll engagement attitude limit of 75°.

Pitch Engagement

ESP engages at 17.5° nose-up and 15.5° nose-down. Once ESP is engaged, it will apply opposing force between 17.5° and 50° nose-up and between 15.5° and 50° nose-down. Maximum opposing force is applied between 22.5° and 50° nose-up and between 20.5° and 50° nose-down.

With ESP engaged, and the aircraft in a nose-up condition, opposing force steadily decreases from 17.5° nose-up to 12.5° nose-up as aircraft pitch moves toward zero degrees. ESP disengages at 12.5° nose-up. With ESP engaged, and the aircraft in a nose-down condition, opposing force steadily decreases from 15.5° nose-down to 10.5° nose-down as aircraft pitch moves toward zero degrees. ESP disengages at 10.5° nose-down.

The opposing force increases or decreases depending on the pitch angle and the direction of pitch travel. This force is intended to encourage movement in the pitch axis in the direction of the normal pitch attitude range for the aircraft.

There are no indications marking the pitch ESP engage and disengage limits in these nose-up/nose-down conditions.

Low Airspeed Protection

Low speed protection is provided as part of the ESP feature. When the stall warning system determines a stall condition is imminent, ESP will engage, applying force in the direction necessary to lower the nose of the aircraft.

High Airspeed Protection

Exceeding V_{ne} will result in ESP applying force to raise the nose of the aircraft. When the high airspeed condition is remedied, ESP force is no longer applied.

PILOT PROFILES

Creating a profile:

- 1) Use the **FMS** Knob to select the AUX - System Setup Page.
 - 2) Press the **FMS** Knob momentarily to activate the flashing cursor.
 - 3) Turn the large **FMS** Knob to highlight 'CREATE' in the Pilot Profile Box.
 - 4) Press the **ENT** Key. A 'Create Profile' window is displayed.
 - 5) Use the **FMS** Knob to enter a profile name up to 16 characters long and press the **ENT** Key. Pilot profile names cannot begin with a blank as the first letter.
 - 6) In the next field, use the small **FMS** Knob to select the desired settings upon which to base the new profile. Profiles can be created based on Garmin factory defaults, default profile settings (initially based on Garmin factory defaults unless edited by the pilot), or current system settings.
 - 7) Press the **ENT** Key.
 - 8) With 'CREATE' highlighted, press the **ENT** Key to create the profile
- Or:**
- Use the large **FMS** Knob to select 'CREATE and ACTIVATE' and press the **ENT** Key to activate the new profile.
- 9) To cancel the process, select 'CANCEL' with the large FMS Knob and press the **ENT** Key.

Selecting an active profile:

- 1) Use the **FMS** Knob to select the AUX - System Setup Page.
- 2) Press the **FMS** Knob momentarily to activate the flashing cursor.
- 3) Turn the large **FMS** Knob to highlight the active profile field in the Pilot Profile Box.
- 4) Turn the small **FMS** Knob to display the pilot profile list and highlight the desired profile.
- 5) Press the **ENT** Key. The system loads and displays the system settings for the selected profile.

Renaming a profile:

- 1) Use the **FMS** Knob to select the AUX - System Setup Page.
- 2) Press the **FMS** Knob momentarily to activate the flashing cursor.
- 3) Turn the large **FMS** Knob to highlight 'RENAME' in the Pilot Profile Box.
- 4) Press the **ENT** Key.
- 5) In the 'Rename Profile' window, turn the **FMS** Knob to select the profile to rename.
- 6) Press the **ENT** Key.
- 7) Use the **FMS** Knob to enter a new profile name up to 16 characters long and press the **ENT** Key.
- 8) With 'RENAME' highlighted, press the **ENT** Key.
- 9) To cancel the process, use the large **FMS** Knob to select 'CANCEL' and press the **ENT** Key.

Deleting a profile:

- 1) Use the **FMS** Knob to select the AUX - System Setup Page.
- 2) Press the **FMS** Knob momentarily to activate the flashing cursor.
- 3) Turn the large **FMS** Knob to highlight 'DELETE' in the Pilot Profile Box.
- 4) Press the **ENT** Key.
- 5) In the 'Delete Profile' window, turn the **FMS** Knob to select the profile to delete.
- 6) Press the **ENT** Key.

- 7) With 'DELETE' highlighted, press the **ENT** Key.
- 8) To cancel the process, use the large **FMS** Knob to select 'CANCEL' and press the **ENT** Key.

Importing a profile:

- 1) Insert the SD card containing the Pilot Profile into the top card slot on the MFD.
- 2) Use the **FMS** Knob to select the AUX - System Setup Page.
- 3) Press the **IMPORT** softkey. If the correct Pilot Profile file is selected; with 'IMPORT' highlighted press the **ENT** Key.

Or:

If the SD card contains more than one Pilot Profile:

- a) Turn the large **FMS** Knob to highlight the select file field in the Pilot Profile Importing Box.
 - b) Turn the small **FMS** Knob to display the pilot profile list and highlight the desired profile to import and press the **ENT** Key.
 - c) With 'IMPORT' highlighted, press the **ENT** Key.
- 4) "Pilot profile import succeeded." is shown in the import results box. Press the **ENT** Key. The imported profile becomes the active Pilot Profile.

Exporting a profile:

- 1) Insert the SD card for storing the Pilot Profile into the top card slot on the MFD.
- 2) Use the **FMS** Knob to select the AUX - System Setup Page.
- 3) Activate the desired Pilot Profile to export. Only the active Pilot Profile can be exported.
- 4) Press the **EXPORT** softkey.
- 5) With 'EXPORT' highlighted press the **ENT** Key.
- 6) "Pilot profile export succeeded." is shown in the export results box. Press the **ENT** Key to exit the Pilot Profile Exporting Box.

POSITION REPORTING

The Position Reporting feature allows the system to send position reporting information to a provider, such as FlightAware.com.

Viewing the Connex Page:

- 1) Turn the large **FMS** Knob on the MFD to select the AUX page group.
- 2) Turn the small **FMS** Knob to select AUX-CONNEX Page.

Setting up Position Reporting:

- 1) With the AUX-CONNEX Page displayed, press the **FMS** Knob to display the cursor in the TRANSMISSION PERIOD field.
- 2) Turn the small **FMS** Knob to select 'AUTO' for automatic transmission of position reports or 'OFF' to disable transmission of position reports.
- 3) Press the **ENT** Key. The selection is entered and the cursor is placed in the TRANSMISSION RATE field.
- 4) Turn the small **FMS** Knob to highlight the first digit.
- 5) Again, turn the small **FMS** Knob to enter the desired number.
- 6) Turn the large **FMS** Knob to highlight the second digit.
- 7) Turn the small **FMS** Knob to enter the desired number.
- 8) Press the **ENT** Key. The selection is entered and the cursor is placed in the PASSENGERS ON BOARD field.
- 9) Turn the small **FMS** Knob left or right to select 'YES' or 'NO'.
- 10) Press the **FMS** Knob to remove the cursor.

To send a position report manually:

- 1) Turn the large **FMS** Knob on the MFD to select the AUX page group.
- 2) Turn the small **FMS** Knob to select AUX-CONNEX Page.
- 3) If necessary, set the TRANSMISSION PERIOD to 'AUTO'.
- 4) Press the **SEND RPT** Softkey.

BLUETOOTH® MANAGEMENT

The Bluetooth Management Page allows for setting up the installed optional Flight Stream device for a Bluetooth connection between the Perspective system and a mobile device running Garmin Pilot™, or other compatible application.

The mobile device must be 'paired' with the Perspective system in order to use the various functions. Pairing is accomplished by first placing the Perspective system in pairing mode by displaying the Bluetooth Management Page. Note the 'PAIRING MODE' field shows 'ENABLED'. The system is 'discoverable' whenever this page is displayed. The pairing operation is completed from the mobile device and Garmin Pilot, or other application.

Viewing the Bluetooth Management Page

- 1) Turn the large **FMS** Knob on the MFD to select the AUX page group.
- 2) Turn the small **FMS** Knob to select the BLUETOOTH MANAGEMENT page.

Changing the Bluetooth Name

- 1) While viewing the Bluetooth Management Page, press the **FMS** Knob to activate the cursor.
- 2) Turn the large **FMS** Knob to place the cursor in the 'BLUETOOTH NAME' field.
- 3) Enter the desired name by using the large **FMS** Knob to select the character field, and the small **FMS** Knob select the desired alphanumeric character for that field.
- 4) Press the **ENT** Key. The cursor is removed and the new name is displayed.

Enabling/Disabling Flight Plan Importing from Garmin Pilot

- 1) While viewing the Bluetooth Management Page, press the **FMS** Knob to activate the cursor.
- 2) Turn the large **FMS** Knob to place the cursor in the 'FLIGHT PLAN IMPORT' field.
- 3) Turn the small **FMS** Knob to select 'ENABLED' or 'DISABLED'.
- 4) Press the **FMS** Knob to remove the cursor.

Enabling/Disabling Automatic Reconnection of a Specific Paired Device

- 1) While viewing the Bluetooth Management Page, press the **FMS** Knob to activate the cursor.
- 2) Turn the large **FMS** Knob to highlight the desired paired device.

- 3) Turn the small **FMS** Knob to select 'ENABLED' or 'DISABLED'. Selecting 'ENABLED' allows the system to automatically connect to a previously paired device when detected.
- 4) Press the **FMS** Knob to remove the cursor.

Remove a Specific Paired Device from the List of Paired Devices:

- 1) While viewing the Bluetooth Management Page, press the **FMS** Knob to activate the cursor.
- 2) Turn the large **FMS** Knob to highlight the desired paired device.
- 3) Press the **REMOVE** Softkey. A confirmation screen is displayed.
- 4) If necessary, turn the large **FMS** Knob to select 'YES'.
- 5) Press the **ENT** Key to remove the device from the list of paired devices.

- Flight Instruments
- EIS
- Nav/Com/XPDR/Audio
- AFCs
- GPS Nav
- Flight Planning
- Procedures
- Hazard Avoidance
- Additional Features**
- Abnormal Operation
- Annun/Alerts
- Appendix
- Index

Blank Page

ABNORMAL OPERATION

REVERSIONARY MODE

Should a system detected failure occur in either display, the Perspective system automatically enters reversionary mode. In reversionary mode, critical flight instrumentation is combined with engine instrumentation on the remaining display.

Reversionary display mode can be manually activated by pressing the **DISPLAY BACKUP** Button on the instrument panel between the PFD and MFD.



NOTE: *The Cirrus SR2x Airplane Flight Manual (AFM) always takes precedence over the information found in this section.*

Engine System Display



NOTE: *Fuel calculations do not use the aircraft fuel quantity indicators and are calculated from the last time the fuel was reset.*



NOTE: *Refer to the Pilot's Operating Handbook (POH) for limitations.*

Accessing the EIS System Display:

- 1) Press the **ENGINE** Softkey.
- 2) Press the **SYSTEM** Softkey.
- 3) To return to the default Engine Display, press the **ENGINE** or **BACK** Softkey.

- Flight Instruments
- EIS
- Nav/Com/XPDR/Audio
- AFCs
- GPS Nav
- Flight Planning
- Procedures
- Hazard Avoidance
- Additional Features
- Abnormal Operation
- Annun/Alerts
- Appendix
- Index

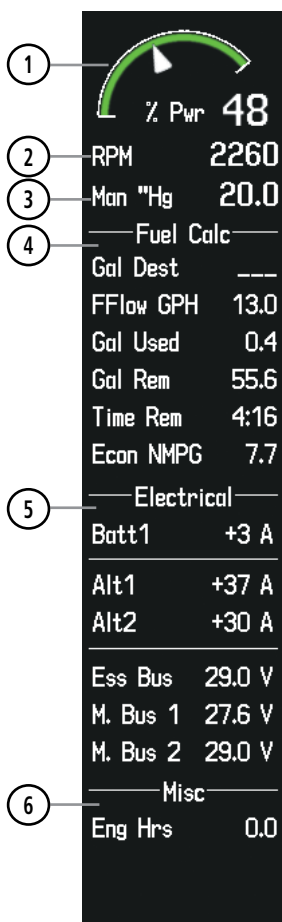

SR20

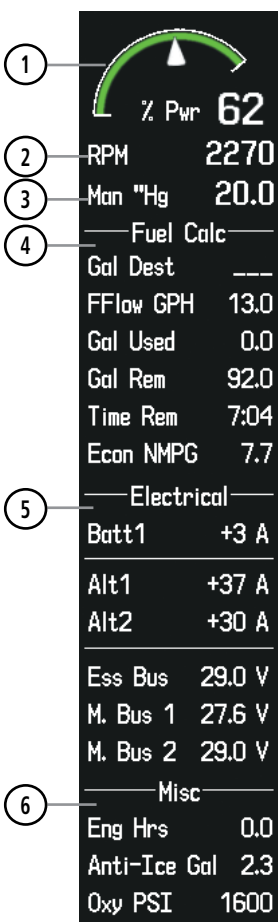

SR22

- ① Percent Power Indicator
- ② Tachometer
- ③ Manifold Pressure
- ④ Fuel Calculation Group

- ⑤ Electrical Group
- ⑥ Miscellaneous
'Anti-Ice Gal' and 'Oxy PSI' are optional on the SR22 models

ABNORMAL COM OPERATION

When a COM tuning failure is detected by the system, the emergency frequency (121.500 MHz) is automatically loaded into the active frequency field of the COM radio for which the tuning failure was detected.

HAZARD DISPLAYS WITH LOSS OF GPS POSITION

If GPS position is lost, or becomes invalid, selected hazards being displayed on the Navigation Map Page are removed until GPS position is again established.



Loss of Hazard Functions with Loss of GPS Position

UNUSUAL ATTITUDES

The PFD ‘declutters’ when the aircraft enters an unusual attitude. Only the primary functions are displayed in these situations.

The following information is removed from the PFD (and corresponding softkeys are disabled) when the aircraft experiences unusual attitudes:

- Traffic Annunciations
- AFCS Annunciations
- Flight Director Command Bars
- Inset Map
- Temperatures
- DME Information Window
- Wind Data
- Selected Heading Box
- Selected Course Box
- Transponder Status Box
- System Time
- PFD Setup Menu
- Windows displayed in the lower right corner of the PFD:
 - Timer/References
 - Nearest Airports
 - Flight Plan
 - Messages
 - Procedures
- Barometric Minimum Descent Altitude Box
- Glideslope, Glidepath, and Vertical Deviation Indicators
- Altimeter Barometric Setting
- Selected Altitude
- VNV Target Altitude



Extreme Pitch Indication

DEAD RECKONING

While in Enroute or Oceanic phase of flight, if the Perspective system detects an invalid GPS solution or is unable to calculate a GPS position, the system automatically reverts to Dead Reckoning (DR) Mode. In DR Mode, the system uses its last-known position combined with continuously updated airspeed and heading data (when available) to calculate and display the aircraft's current estimated position.



NOTE: *Dead Reckoning Mode only functions in Enroute (ENR) or Oceanic (OCN) phase of flight. In all other phases, an invalid GPS solution produces a "NO GPS POSITION" annunciation on the map and the system stops navigating in GPS Mode.*

DR Mode is indicated by the appearance of the letters 'DR' superimposed in yellow over the 'own aircraft' symbol as shown in the following figure. In addition, 'DR' is prominently displayed, also in yellow, on the HSI slightly above and to the right of the aircraft symbol on the CDI as shown in the following figure. Also, the CDI deviation bar is displayed in yellow. Lastly, but at the same time, a 'GPS NAV LOST' alert message appears on the PFD.

Normal navigation using GPS/SBAS source data resumes automatically once a valid GPS solution is restored.

It is important to note that estimated navigation data supplied by the system in DR Mode may become increasingly unreliable and must not be used as a sole means of navigation. If, while in DR Mode, airspeed and/or heading data is also lost or not available, the DR function may not be capable of estimating your position and, consequently, the system may display a path that is different than the actual movement of the aircraft. Estimated position information displayed by the system through DR while there is no heading and/or airspeed data available should not be used for navigation.

DR Mode is inherently less accurate than the standard GPS/SBAS Mode due to the lack of satellite measurements needed to determine a position. Changes in wind speed and/or wind direction compounds the relative inaccuracy of DR Mode. Because of this degraded accuracy, the crew must maintain position awareness using other navigation equipment until GPS-derived position data is restored.



CDI 'DR' Indication on PFD



Symbolic Aircraft
(Map pages and Inset Map)

Dead Reckoning Indications

As a result of operating in DR Mode, all GPS-derived data is computed based upon an estimated position and is displayed as yellow text on the display to denote degraded navigation source information. This data includes the following:

- Navigation Status Box fields except Active Leg, TAS, and DTK
- Course Deviation Indicator
- GPS Bearing Pointer
- Wind data and pointers in the Wind Data Box on the PFD
- Track Indicator
- All Bearing Pointer Distances
- Active Flight Plan distances, bearings, and ETE values

Also, while the system is in DR Mode, the autopilot will not couple to GPS, and Terrain Proximity, TERRAIN-SVT, and TAWS are disabled. Additionally, the accuracy of all nearest information (airports, airspaces, and waypoints) is questionable. Finally, airspace alerts continue to function, but with degraded accuracy.

Flight Instruments

EIS

Nav/Com/XPDR/Audio

AFCs

GPS Nav

Flight Planning

Procedures

Hazard Avoidance

Additional Features

Abnormal Operation

Annun/Alerts

Appendix

Index

Blank Page

ANNUNCIATIONS & ALERTS

PERSPECTIVE SYSTEM ANNUNCIATIONS





When an LRU or an LRU function fails, a large red “X” is typically displayed on windows associated with the failed data. Refer to the AFM for additional information regarding pilot responses to these annunciations

System Annunciation	Comment
<p>AHRS ALIGN: Keep Wings Level</p>	Attitude and Heading Reference System is aligning.
<p>ATTITUDE FAIL</p>	Display system is not receiving attitude information from the AHRS.
<p>CALIBRATE AHRS/MAG</p>	AHRS calibration incomplete or configuration module failure.
<p>CHECK ATTITUDE</p>	This annunciation is seen only when the autopilot is engaged. The annunciation indicates an AHRS monitor has detected an abnormal flight parameter, possibly caused by strong turbulence. In this case, the situation should correct itself within a few seconds. If there is an actual failure, a red “X” soon appears over the Attitude Indicator.

- Flight Instruments
- EIS
- Nav/Com/XPDR/Audio
- AFCS
- GPS Nav
- Flight Planning
- Procedures
- Hazard Avoidance
- Additional Features
- Abnormal Operation
- Annun/Alerts
- Appendix
- Index

- Flight Instruments
- EIS
- Nav/Com/XPDR/Audio
- AFCs
- GPS Nav
- Flight Planning
- Procedures
- Hazard Avoidance
- Additional Features
- Abnormal Operation
- Annun/Alerts
- Appendix
- Index

System Annunciation	Comment
	<p>GPS information is either not present or is invalid for navigation use. Note that AHRS utilizes GPS inputs during normal operation. AHRS operation may be degraded if GPS signals are not present (see the current version of the pertinent flight manual).</p>
	<p>CDI is not receiving valid data from the corresponding GIA. Does not apply when the CDI is set to GPS.</p>
	<p>Display system is not receiving airspeed input from air data computer.</p>
	<p>Display system is not receiving vertical speed input from the air data computer.</p>
	<p>System is not receiving valid heading input from GMU, but is receiving GPS-derived track information.</p>
	<p>System is not receiving valid heading input from GMU and is not receiving GPS-derived track information.</p>

System Annunciation	Comment
	Display system is not receiving altitude input from the air data computer.
	Display system is not receiving valid true airspeed information from air data computer.
	Display system is not receiving valid OAT information from air data computer.
	Display system is not receiving valid transponder information.
	Different versions of GDU software are installed in the PFD and MFD. This can also indicate different versions of the navigation database installed in the PFD and MFD. A cross-talk error between the PFD and MFD will also cause this annunciation.
Other Various Red X Indications	A red 'X' through any other display field (such as engine instrumentation fields) indicates that the field is not receiving valid data.

WARNING ALERTS

Annunciation Window Text	Alerts Window Text	Audio Alert
ANTI ICE CTL ☁	Tank valves cannot be controlled (closed) (TKS).	Repeating Double Chime
ANTI ICE FLOW ☁	Flow rate is low (TKS).	Repeating Double Chime
ANTI ICE QTY ☁	Left and right fluid quantities are unknown (TKS)	Repeating Double Chime
ANTI ICE QTY ☁ ☁	Fluid quantity is low (TKS).	Repeating Double Chime
AOA OVERHEAT ☁	AOA probe is overheated.	Repeating Double Chime

	Annunciation Window Text	Alerts Window Text	Audio Alert
Flight Instruments	AUTO DESCENT†	Automatic descent to 14,000FT in 60 seconds.	Repeating Double Chime
EIS	AUTO DESCENT†	Aircraft descending to 14,000FT.	Repeating Double Chime
Nav/Com/XPDR/Audio	AUTO DESCENT†	Aircraft descending to 12,500FT.	Repeating Double Chime
AFCs	AUTO DESCENT†	Aircraft descended due to pilot incapacitation.	Repeating Double Chime
	BRAKE TEMP	Brake temperature is high.	Repeating Double Chime
	CHT	Cylinder head temperature is high.	Repeating Double Chime
	CO LVL HIGH	Carbon monoxide level is too high.	Repeating Double Chime
GPS Nav	ESS BUS	Check essential power bus voltage.	Repeating Double Chime ¹
Flight Planning	FLAPS ICE ☁️ ❄️	Full flaps prohibited in icing conditions.	Repeating Double Chime
Procedures	FUEL FLOW*	Check fuel flow.	Repeating Double Chime
	FUEL IMBALANCE	Fuel quantity imbalance has been detected.	Repeating Double Chime
	FUEL QTY	Check fuel tank levels.	Repeating Double Chime
Hazard Avoidance	M BUS 1	Check main power bus 1 voltage.	Repeating Double Chime
	M BUS 2	Check main power bus 2 voltage.	Repeating Double Chime
Additional Features	MAN PRESSURE*	Check manifold pressure.	Repeating Double Chime (after 30 seconds)
	OIL PRESSURE	Oil pressure is out of range.	Repeating Double Chime ¹
Abnormal Operation	OIL TEMP	Oil temperature is high.	Repeating Double Chime
	OXYGEN FAULT⁺	Oxygen system fault.	Repeating Double Chime
	OXYGEN QTY⁺	Oxygen quantity is low.	Repeating Double Chime
Annun/Alerts	PITCH TRIM	Pitch Trim control has failed.	Repeating Double Chime
	RPM	Check engine RPM.	Repeating Double Chime
Appendix	SPIN SPIN SPIN	Spin entry detected.	"Spin Spin Spin" (repeating)
	STALL	Stall warning.	"Stall" Repeating with Continuous Tone
Index	STALL WARN FAIL	Stall warning is inoperative.	Repeating Double Chime

Annunciation Window Text	Alerts Window Text	Audio Alert
START ENGAGED	Starter is engaged.	Repeating Double Chime
TIT*	TIT temperature is high.	Repeating Double Chime
UNDERSPEED PROTECT ACTIVE†	None	"Airspeed"

✦ Optional / * Not applicable to all models / 🛩 TKS NH (optional) / 🛩 TKS FIKI (optional) /

¹ In air only / ^ SR22T only / † Garmin AFCS required

CAUTION ALERTS

Annunciation Window Text	Alerts Window Text	Audio Alert
ALT 1	Check alternator 1 current.	Double Chime ¹
ALT 2	Check alternator 2 current.	Double Chime ¹
ALT AIR OPEN*	Alternate air door is open.	Double Chime
ANTI ICE HEAT ☁	Stall warning/AoA heater has failed.	Double Chime
ANTI ICE LEVEL ☁	Left tank fluid quantity is unreliable (TKS).	Double Chime
ANTI ICE LEVEL ☁	Right tank fluid quantity is unreliable (TKS).	Double Chime
ANTI ICE PRESS ☁	Tail pressure is low (TKS).	Double Chime
ANTI ICE PRESS ☁	Pressure is high (TKS).	Double Chime
ANTI ICE QTY ☁	Fluid quantity imbalance has been detected (TKS)	Double Chime
ANTI ICE QTY ☁	Fluid quantity is low (TKS)	Double Chime
ANTI ICE SPEED ☁	Airspeed is too low for ice protection (TKS).	Double Chime ¹
ANTI ICE SPEED ☁	Airspeed is too high for ice protection (TKS).	Double Chime ¹
ANTI ICE TEMP ☁	Temperature is too low for ice protection (TKS)	None
AP MISCOMPARE †	Autopilot miscompare, autopilot is not available.	Double Chime
AP/PFD DIF ADC †	Autopilot and PFD are using different ADCs.	Double Chime
AP/PFD DIF AHRS †	Autopilot and PFD are using different AHRSs.	Double Chime
AVIONICS OFF	Avionics master switch is off.	Double Chime
BATT 1	Check battery 1 current.	Double Chime ¹

	Annunciation Window Text	Alerts Window Text	Audio Alert
Flight Instruments	BRAKE TEMP	Brake temperature is high.	Double Chime
EIS	CHT	Cylinder head temperature is high.	Double Chime
Nav/Com/XPDR/Audio	FLAP OVERSPEED	Flaps are extended beyond airspeed limitations.	Double Chime
	FUEL FILTER	Fuel filter in bypass	Double Chime
	FUEL IMBALANCE	Fuel quantity imbalance has been detected.	None
	FUEL QTY	Check fuel tank levels.	Double Chime
AFCs	HYPOXIA ALERT†	Hypoxia caution alert.	Double Chime
GPS Nav	LRG MAG VAR	The GDU's internal model cannot determine the exact magnetic variance for geographic locations near the magnetic poles. Displayed magnetic course angles may differ from the actual magnetic heading by more than 2°.	Double Chime
Flight Planning	M BUS 1	Check main power bus 1.	Double Chime ¹
	M BUS 2	Check main power bus 2.	Double Chime ¹
Procedures	MAN PRESSURE*	Check manifold pressure.	None
	NO ADC MODES*	Autopilot air data modes are not available.	Double Chime
	NO VERT MODES*	Autopilot vertical modes are not available.	Double Chime
Hazard Avoidance	OIL PRESSURE	Oil pressure is out of range.	Double Chime ¹
	OIL TEMP	Oil temperature is high.	Double Chime
Additional Features	OXYGEN QTY*	Oxygen quantity is low.	Double Chime
	OXYGEN RQD*	Oxygen is required.	Double Chime
Abnormal Operation	PARK BRAKE	Parking break is set.	None
	PITOT HEAT FAIL	Pitot heat failure.	Double Chime
	PITOT HEAT REQD	Pitot heat is required.	Double Chime ¹
Annun/Alerts	SLCT MAG	The system notifies the pilot to set the Nav Angle units on the Avioncs Settings Screen to Magnetic.	Double Chime
Appendix	SLCT NON-MAG	The system notifies the pilot to set the Nav Angle units on the Avioncs Settings Screen to True.	Double Chime
Index			

Annunciation Window Text	Alerts Window Text	Audio Alert
START ENGAGED	Starter is engaged.	Double Chime
TAKEOFF FLAPS	Flaps not in takeoff configuration	Double Chime

✦ Optional / * Not applicable to all models / 🛩️ TKS NH (optional) / 🛩️ TKS FIKI (optional) /

¹ In air only / † Garmin AFCS required

ADVISORY ANNUNCIATIONS

Annunciation Window Text	Alerts Window Text	Audio Alert
ALTITUDE SEL ✦	Climbing away from selected altitude.	None
ALTITUDE SEL ✦	Descending away from selected altitude.	None
AOA FAIL 🛩️	Dynamic stall speed band is not available.	None
ARE YOU ALERT? †	Are you alert?	None
COURSE SEL ✦	Current track will not intercept selected course.	None
CHECK FUEL §	Fuel quantity imbalance has been detected.	None
FUEL IMBALANCE ^	Fuel quantity imbalance has been detected.	None
HIGH MP FF *	Avoid fuel flow 18 to 30 GPH and MP above 26".	None
L FUEL QTY	Check left fuel tank level.	None
OXYGEN LEFT ON ✦	Oxygen system is left on after shutdown.	Double Chime
OXYGEN QTY ✦	Oxygen quantity is low.	None
PUMP BACKUP 🛩️	Anti-ice backup pump mode has been selected (TKS).	None
R FUEL QTY	Check right fuel tank level.	None
ROL MODE	Roll mode is active.	None

✦ Optional / * Not applicable to all models / 🛩️ TKS FIKI (optional) / † Garmin AFCS required / ^ SR22 models only / § SR20 model only

COMPARATOR ANNUNCIATIONS

Comparator Window Text	Condition
ALT MISCOMP	Difference in altitude sensors is ≥ 200 ft.
IAS MISCOMP	If both airspeed sensors detect < 35 knots, this is inhibited.
	If either airspeed sensor detects ≥ 35 knots, and the difference in sensors is > 10 kts.
	If either airspeed sensor detects ≥ 80 knots, and the difference in sensors is > 7 kts.
HDG MISCOMP	Difference in heading sensors is > 6 degrees.
PIT MISCOMP	Difference in pitch sensors is > 5 degrees.
ROL MISCOMP	Difference in roll sensors is > 6 degrees.
ALT NO COMP	No data from one or both altitude sensors.
IAS NO COMP	No data from one or both airspeed sensors.
HDG NO COMP	No data from one or both heading sensors.
PIT NO COMP	No data from one or both pitch sensors.
ROL NO COMP	No data from one or both roll sensors..

Dual AHRS and/or dual Air Data Computer installations only

REVERSIONARY SENSOR ANNUNCIATIONS

Reversionary Sensor Window Text	Condition
USING ADC2	The PFD is displaying data from the #2 Air Data Computer (dual ADCs only)
USING AHR2	The PFD is displaying data from the #2 AHRS (dual AHRS only).

Dual AHRS and/or dual Air Data Computer installations only

MESSAGE ADVISORY ALERTS

Alerts Window Message	Audio Alert
ANTI ICE QTY – Fluid quantity is low (TKS)	None
CO DET FAIL – The carbon monoxide detector is inoperative	
CO DET SRVC – The carbon monoxide detector needs service	
ESP CONFIG † – ESP config error. Config service req'd.	
ESP FAIL † – ESP is inoperative.	
ESP OFF † – ESP selected off.	
ESP DEGRADE † – ESP IAS mode is inoperative.	
EXIT ICING – Exit icing conditions	
FAILED PATH – An autopilot servo data path has failed	
MFD FAN FAIL – MFD cooling fan is inoperative.	
PFD FAN FAIL – PFD cooling fan is inoperative.	

✦ Optional/ TKS NH (optional)/ TKS FIKI (optional) † Garmin AFCS required

GARMIN AFCS ALERTS

Condition	Annunciation	Description
Rudder Mistrim Right		Yaw servo providing sustained force in the indicated direction
Rudder Mistrim Left		
Aileron Mistrim Right		Roll servo providing sustained force in the indicated direction
Aileron Mistrim Left		
Elevator Mistrim Down		Pitch servo providing sustained force in the indicated direction
Elevator Mistrim Up		
Pitch Trim Failure		If AP engaged, take control of the aircraft and disengage AP If AP disengaged, move MET switch to unstick

Condition	Annunciation	Description
Yaw Damper Failure		YD control failure
Roll Failure		Roll axis control failure; AP inoperative
Pitch Failure		Pitch axis control failure
System Failure		AP and MET are unavailable; FD may still be available
Preflight Test		Performing preflight system test. Do not press the AP DISC Button during servo power-up and preflight system tests as this may cause the preflight system test to fail or never to start (if servos fail their power-up tests). Power must be cycled to the servos to remedy the situation.
		Preflight system test failed; aural alert sounds at failure
Hypoxia Recognition System is activated		Activated only by the Hypoxia Recognition System

GARMIN AFCS SPEED CONDITION/STALL ALERT

Condition	Annunciation	Description
Overspeed		Flashing annunciation indicating aircraft overspeed condition. The autopilot, if engaged, will follow the pitch up command for the flight director. Engine power should be reduced and/or the pitch reference adjusted to slow the aircraft. The annunciation disappears when the overspeed condition is resolved.

Condition	Annunciation	Description
Underspeed/Stall	MINSPEED	Flashing annunciation indicating aircraft underspeed or imminent stall condition. An underspeed condition initiates flight director commands for pitch down and, if engaged, the autopilot will follow the pitch down command. Engine power should be increased and/or the pitch reference adjusted to increase airspeed. A stall condition causes the flight director to capture the Stall Warning Reference Airspeed (i.e., the speed at which Stall Warning Mode was entered) and commands a pitch attitude to follow the reference speed. The Stall Warning Reference Airspeed is increased at a rate of one kt/sec. The annunciation disappears when the condition is resolved.

TERRAIN-SVT ALERTS

Alert Type	PFD/MFD TERRAIN-SVT Page Annunciation	MFD Pop-Up Alert	Voice Message
Reduced Required Terrain Clearance Warning (RTC)	TERRAIN	WARNING - TERRAIN	"Warning; Terrain, Terrain"
Imminent Terrain Impact Warning (ITI)	TERRAIN	WARNING - TERRAIN	"Warning; Terrain, Terrain"
Reduced Required Obstacle Clearance Warning (ROC)	TERRAIN	WARNING - OBSTACLE	"Warning; Obstacle, Obstacle"
Imminent Obstacle Impact Warning (IOI)	TERRAIN	WARNING - OBSTACLE	"Warning; Obstacle, Obstacle"
Reduced Required Terrain Clearance Caution (RTC)	TERRAIN	CAUTION - TERRAIN	"Caution; Terrain, Terrain"
Imminent Terrain Impact Caution (ITI)	TERRAIN	CAUTION - TERRAIN	"Caution; Terrain, Terrain"
Reduced Required Obstacle Clearance Caution (ROC)	TERRAIN	CAUTION - OBSTACLE	"Caution; Obstacle, Obstacle"
Imminent Obstacle Impact Caution (IOI)	TERRAIN	CAUTION - OBSTACLE	"Caution; Obstacle, Obstacle"

TERRAIN-SVT SYSTEM STATUS ANNUNCIATIONS

Alert Type	PFD/MFD Alert Annunciation	TERRAIN-SVT Page Annunciation	Voice Message
System Test in Progress	TER TEST	TERRAIN TEST	None
System Test Pass	None	None	"Terrain System Test OK"
Terrain Alerting is disabled	TER INH	None	None
MFD Terrain or Obstacle database unavailable or invalid. Terrain-SVT operating with PFD Terrain or Obstacle databases	None	TERRAIN DATABASE FAILURE	None
Terrain System Test Fail	TER FAIL	TERRAIN FAIL	"Terrain System Failure"
Terrain or Obstacle database unavailable or invalid, invalid software configuration, system audio fault	TER FAIL	TERRAIN FAIL	"Terrain System Failure"
No GPS position	TER N/A	NO GPS POSITION	"Terrain System Not Available"
Excessively degraded GPS signal, Out of database coverage area	TER N/A	None	"Terrain System Not Available"
Sufficient GPS signal received after loss	None	None	"Terrain System Available"

- Flight Instruments
- EIS
- Nav/Com/XPDR/Audio
- AFCs
- GPS Nav
- Flight Planning
- Procedures
- Hazard Avoidance
- Additional Features
- Abnormal Operation
- Annun/Alerts
- Appendix
- Index

TAWS-B ALERTS

Alert Type	PFD/MFD TAWS-B Page Annunciation	MFD Pop-Up Alert	Voice Message
Excessive Descent Rate Warning (EDR)	PULL UP	PULL-UP	"Pull Up"
Reduced Required Terrain Clearance Warning (RTC)	PULL UP	TERRAIN - PULL-UP or TERRAIN AHEAD - PULL-UP	"Terrain, Terrain; Pull Up, Pull Up" or "Terrain Ahead, Pull Up; Terrain Ahead, Pull Up"
Imminent Terrain Impact Warning (ITI)	PULL UP	TERRAIN AHEAD - PULL-UP or TERRAIN - PULL-UP	Terrain Ahead, Pull Up; Terrain Ahead, Pull Up" or "Terrain, Terrain; Pull Up, Pull Up"
Reduced Required Obstacle Clearance Warning (ROC)	PULL UP	OBSTACLE - PULL-UP or OBSTACLE AHEAD - PULL-UP	"Obstacle, Obstacle; Pull Up, Pull Up" or "Obstacle Ahead, Pull Up; Obstacle Ahead, Pull Up"
Imminent Obstacle Impact Warning (IOI)	PULL UP	OBSTACLE AHEAD - PULL-UP or OBSTACLE - PULL-UP	"Obstacle Ahead, Pull Up; Obstacle Ahead, Pull Up" or "Obstacle, Obstacle; Pull Up, Pull Up"
Reduced Required Terrain Clearance Caution (RTC)	TERRAIN	CAUTION - TERRAIN or TERRAIN AHEAD	"Caution, Terrain; Caution, Terrain" or "Terrain Ahead; Terrain Ahead"
Imminent Terrain Impact Caution (ITI)	TERRAIN	TERRAIN AHEAD or CAUTION - TERRAIN	"Terrain Ahead; Terrain Ahead" or "Caution, Terrain; Caution, Terrain"

Alert Type	PFD/MFD TAWS-B Page Annunciation	MFD Pop-Up Alert	Voice Message
Reduced Required Obstacle Clearance Caution (ROC)	TERRAIN	CAUTION - OBSTACLE or OBSTACLE AHEAD	"Caution, Obstacle; Caution, Obstacle" or "Obstacle Ahead; Obstacle Ahead"
Imminent Obstacle Impact Caution (IOI)	TERRAIN	OBSTACLE AHEAD or CAUTION - OBSTACLE	"Obstacle Ahead; Obstacle Ahead" or "Caution, Obstacle; Caution, Obstacle"
Premature Descent Alert Caution (PDA)	TERRAIN	TOO LOW - TERRAIN	"Too Low, Terrain"
Altitude Callout (VCO) "500" "600"	None	None	"Five-Hundred" "Six-Hundred"
Excessive Descent Rate Caution (EDR)	TERRAIN	SINK RATE	"Sink Rate"
Negative Climb Rate Caution (NCR)	TERRAIN	DON'T SINK or TOO LOW - TERRAIN	"Don't Sink" or "Too Low, Terrain"

TAWS-B SYSTEM STATUS ANNUNCIATIONS

Alert Cause	PFD/MFD Annunciation	TAWS-B Page Annunciation	Voice Alert
MFD Terrain or Obstacle database unavailable or invalid. TAWS operating with PFD Terrain or Obstacle databases	None	TERRAIN DATABASE FAILURE	None

Alert Cause	PFD/MFD Annunciation	TAWS-B Page Annunciation	Voice Alert
Terrain or Obstacle database unavailable or invalid on all displays, invalid software configuration, TAWS audio fault	TAWS FAIL	TAWS FAIL	"TAWS System Failure"
No GPS position	TAWS N/A	NO GPS POSITION	"TAWS Not Available" "TAWS Available" when GPS position returns.
Excessively degraded GPS signal	TAWS N/A	None	"TAWS Not Available" "TAWS Available" when sufficient GPS signal is received.
Out of database coverage area	TAWS N/A	None	"TAWS Not Available" "TAWS Available" when aircraft enters database coverage area.

VOICE ALERTS

Voice Alert	Description
"Airspeed"	Low airspeed when the autopilot is engaged (Garmin AFCS only).
"Minimums, minimums"	The aircraft has descended below the preset minimum descent altitude or decision altitude.
"Traffic, Traffic"	Played when a Traffic Advisory (TA) is issued (optional).
"Traffic Advisory System Test Passed"	Played when the Skywatch TAS system passes a pilot-initiated self test (optional).

- Flight Instruments
- EIS
- Nav/Com/XPDR/Audio
- AFCS
- GPS Nav
- Flight Planning
- Procedures
- Hazard Avoidance
- Additional Features
- Abnormal Operation
- Annun/Alerts
- Appendix
- Index

	Voice Alert	Description
Flight Instruments	"Traffic Advisory System Test Failed"	Played when the Skywatch TAS system fails a pilot-initiated self test (optional).
EIS	"Vertical track"	The aircraft is one minute from Top of Descent. Issued only when vertical navigation is enabled.
Nav/Com/XPDR/Audio	"One o'clock" through "Twelve o'clock" or "No Bearing"	Played to indicate bearing of traffic from own aircraft (GTS 800 only).
AFCs	"High", "Low", "Same Altitude" (if within 200 feet of own altitude), or "Altitude not available"	Played to indicate altitude of traffic relative to own aircraft (GTS 800 only).
GPS Nav	"Less than one mile", "One Mile" through "Ten Miles", or "More than ten miles"	Played to indicate distance of traffic from own aircraft (GTS 800 only).
Flight Planning		

CO GUARDIAN MESSAGES

	Alerts Window Message	Comments
Hazard Avoidance	CO DET SRVC – The carbon monoxide detector needs service.	There is a problem within the CO Guardian that requires service.
Additional Features	CO DET FAIL – The carbon monoxide detector is inoperative.	Loss of communication between the Perspective system and the CO Guardian.

SYSTEM MESSAGE ADVISORIES

	Message	Comments
Annun/Alerts	ABORT APR – Loss of GPS navigation. Abort approach.	Abort approach due to loss of GPS navigation.
Appendix	ADC1 ALT EC – ADC1 altitude error correction is unavailable.	GDC1 or GDC2 is reporting that the altitude error correction is unavailable.
	ADC2 ALT EC – ADC2 altitude error correction is unavailable.	

Message	Comments
ADC1 AS EC – ADC 1 airspeed error correction is unavailable.	GDC1 or GDC2 is reporting that the airspeed error correction is unavailable.
ADC2 AS EC – ADC 2 airspeed error correction is unavailable.	
AHRS1 TAS – AHRS1 not receiving valid airspeed.	The #1 AHRS is not receiving true airspeed from the air data computer. The AHRS relies on GPS information to augment the lack of airspeed. The Perspective system should be serviced.
AHRS2 TAS – AHRS2 not receiving valid airspeed.	The #2 AHRS is not receiving true airspeed from the air data computer. The AHRS relies on GPS information to augment the lack of airspeed. The Perspective system should be serviced.
AHRS1 GPS – AHRS1 using backup GPS source.	The #1 AHRS is using the backup GPS path. Primary GPS path has failed. The Perspective system should be serviced when possible.
AHRS2 GPS – AHRS2 using backup GPS source.	The #2 AHRS is using the backup GPS path. Primary GPS path has failed. The Perspective system should be serviced when possible.
AHRS1 GPS – AHRS1 not receiving any GPS information.	The #1 AHRS is not receiving any or any useful GPS information. Check the current version of the pertinent flight manual limitations. The Perspective system should be serviced.
AHRS2 GPS – AHRS2 not receiving any GPS information.	The #2 AHRS is not receiving any or any useful GPS information. Check the current version of the pertinent flight manual limitations. The Perspective system should be serviced.
AHRS1 GPS – AHRS1 not receiving backup GPS information.	The #1 AHRS is not receiving backup GPS information. The Perspective system should be serviced.
AHRS2 GPS – AHRS2 not receiving backup GPS information.	The #2 AHRS is not receiving backup GPS information. The Perspective system should be serviced.
AHRS1 GPS – AHRS1 operating exclusively in no-GPS mode.	The #1 AHRS is operating exclusively in no-GPS mode. The Perspective system should be serviced.

Flight Instruments

EIS

Nav/Com/XPDR/Audio

AFCS

GPS Nav

Flight Planning

Procedures

Hazard Avoidance

Additional Features

Abnormal Operation

Annun/Alerts

Appendix

Index

	Message	Comments
Flight Instruments	AHRS2 GPS – AHRS2 operating exclusively in no-GPS mode.	The #2 AHRS is operating exclusively in no-GPS mode. The Perspective system should be serviced.
EIS	AHRS MAG DB – AHRS magnetic model database version mismatch.	The #1 AHRS earth magnetic field model is out of date. Update magnetic field model when practical.
Nav/Com/XPDR/Audio	AHRS1 SRVC – AHRS1 Magnetic-field model needs update.	The #1 AHRS earth magnetic field model is out of date. Update magnetic field model when practical.
AFCs	AHRS2 SRVC – AHRS2 Magnetic-field model needs update.	The #2 AHRS earth magnetic field model is out of date. Update magnetic field model when practical.
GPS Nav	APPR INACTV – Approach is not active.	The system notifies the pilot that the loaded approach is not active. Activate approach when required.
Flight Planning	APR DWNGRADE – Approach downgraded.	Vertical guidance generated by SBAS is unavailable, use LNAV only minimums.
Procedures	ARSPC AHEAD – Airspace ahead less than 10 minutes.	Special use airspace is ahead of aircraft. The aircraft will penetrate the airspace within 10 minutes.
Hazard Avoidance	ARSPC NEAR – Airspace near and ahead.	Special use airspace is near and ahead of the aircraft position.
Additional Features	ARSPC NEAR – Airspace near – less than 2 nm.	Special use airspace is within 2 nm of the aircraft position.
Abnormal Operation	CHECK CRS – Database course for LOC1 / [LOC ID] is [CRS]°.	Selected course for LOC1 differs from published localizer course by more than 10 degrees.
Annun/Alerts	CHECK CRS – Database course for LOC2 / [LOC ID] is [CRS]°.	Selected course for LOC2 differs from published localizer course by more than 10 degrees.
Appendix	CNFG MODULE – PFD1 configuration module is inoperative.	The PFD1 configuration module backup memory has failed. The system should be serviced.
Index	COM1 CONFIG – COM1 config error. Config service req'd.	The COM1 and/or COM2 configuration settings do not match backup configuration memory. The system should be serviced.
	COM2 CONFIG – COM2 config error. Config service req'd.	

Message	Comments
COM1 PTT – COM1 push-to-talk key is stuck.	The COM1 and/or COM2 external push-to-talk switch is stuck in the enable (or “pressed”) position. Press the PTT switch again to cycle its operation. If the problem persists, the system should be serviced.
COM2 PTT – COM2 push-to-talk key is stuck.	
COM1 RMT XFR – COM1 remote transfer key is stuck.	The COM1 and/or COM2 transfer switch is stuck in the enabled (or “pressed”) position. Press the transfer switch again to cycle its operation. If the problem persists, the system should be serviced.
COM2 RMT XFR – COM2 remote transfer key is stuck.	
COM1 SERVICE – COM1 needs service. Return unit for repair.	The system has detected a fault in COM1 and/or COM2. COM1 and/or COM2 may still be usable. The system should be serviced when possible.
COM2 SERVICE – COM2 needs service. Return unit for repair.	
COM1 TEMP – COM1 over temp. Reducing transmitter power.	The system has detected an over temperature condition in COM1 and/or COM2. The transmitter operates at reduced power. If the problem persists, the system should be serviced.
COM2 TEMP – COM2 over temp. Reducing transmitter power.	
DATA LOST – Pilot stored data was lost. Recheck settings.	The pilot profile data was lost. System reverts to default pilot profile and settings. The pilot may reconfigure the MFD & PFD with preferred settings, if desired.
DB CHANGE – Database changed. Verify user modified procedures.	This occurs when a stored flight plan contains an airway that is no longer consistent with the navigation database. This alert is issued only after an navigation database update. Verify that the user-modified procedures in stored flight plans are correct and up to date.
DB CHANGE – Database changed. Verify stored airways.	This occurs when a stored flight plan contains an airway that is no longer consistent with the navigation database. This alert is issued only after an navigation database update. Verify use of airways in stored flight plans and reload airways as needed.

- Flight Instruments
- EIS
- Nav/Com/XPDR/Audio
- AFCS
- GPS Nav
- Flight Planning
- Procedures
- Hazard Avoidance
- Additional Features
- Abnormal Operation
- Annun/Alerts
- Appendix
- Index

Message	Comments
DB MISMATCH – Navigation database mismatch. Xtalk is off.	The PFD and MFD have different navigation database versions or regions installed. Crossfill is off. Check the AUX-SYSTEM STATUS Page to determine versions or regions. Also, check the AUX-SYSTEM STATUS Page for a database synchronization function not completed. After synchronization is complete, power must be turned off, then on.
DB MISMATCH – Standby Navigation database mismatch.	The PFD and MFD have different standby navigation database versions or regions installed. Check the AUX-SYSTEM STATUS Page to determine versions or regions. Also, check the AUX-SYSTEM STATUS Page for a database synchronization function not completed. After synchronization is complete, power must be turned off, then on.
DB MISMATCH – Terrain database mismatch.	The PFD and MFD have different terrain database versions or regions installed. Check the AUX-SYSTEM STATUS Page to determine versions or regions. Also, check the AUX-SYSTEM STATUS Page for a database synchronization function not completed. After synchronization is complete, power must be turned off, then on.
DB MISMATCH – Obstacle database mismatch.	The PFD and MFD have different obstacle database versions or regions installed. Check the AUX-SYSTEM STATUS Page to determine versions or regions. Also, check the AUX-SYSTEM STATUS Page for a database synchronization function not completed. After synchronization is complete, power must be turned off, then on.
FAILED PATH – A data path has failed.	A data path connected to the GDU or the GIA 63/W has failed.

Message	Comments
FPL WPT LOCK – Flight plan waypoint is locked.	<p>Upon power-up, the system detects that a stored flight plan waypoint is locked. This occurs when an navigation database update eliminates an obsolete waypoint. The flight plan cannot find the specified waypoint and flags this message. This can also occur with user waypoints in a flight plan that is deleted.</p> <p>Remove the waypoint from the flight plan if it no longer exists in any database, Or Update the waypoint name/identifier to reflect the new information.</p>
FPL WPT MOVE – Flight plan waypoint moved.	The system has detected that a waypoint coordinate has changed due to a new navigation database update. Verify that stored flight plans contain correct waypoint locations.
FPL TRUNC – Flight plan has been truncated.	This occurs when a newly installed navigation database eliminates an obsolete approach or arrival used by a stored flight plan. The obsolete procedure is removed from the flight plan. Update flight plan with current arrival or approach.
GCU CNFG – GCU Config error. Config service req'd.	GCU 478 configuration settings do not match those of backup configuration memory. The Perspective system should be serviced.
GCU FAIL – GCU is inoperative.	A fault has been detected in the GCU 478. The GCU 478 is unavailable.
GCU FAIL – GCU is inoperative.	A fault has been detected in the GMC 705. The GMC 705 is unavailable.
GCU KEYSTK – GCU [key name] Key is stuck.	A key is stuck on the GCU 478 bezel. Attempt to free the stuck key by pressing it several times. The Perspective system should be serviced if the problem persists.

	Message	Comments
Flight Instruments	GCU KEYSTK – GCU [key name] Key is stuck.	A key is stuck on the GMC 705 bezel. Attempt to free the stuck key by pressing it several times. The Perspective system should be serviced if the problem persists.
EIS	GDL59 CONFIG – GDL 59 config error. Config service req'd.	GDL 59 configuration settings do not match those of backup configuration memory. The system should be serviced.
Nav/Com/XPDR/Audio	GDL59 FAIL – GDL 59 has failed.	A fault has been detected in the GDL 59. The receiver is unavailable. The system should be serviced.
AFC	GDL59 SERVICE – GDL 59 needs service. Return unit for repair.	A fault has been detected in the GDL 59. The system should be serviced.
GPS Nav	GDL59 RTR FAIL – The GDL 59 router has failed.	A fault has been detected in the GDL 59 router. The system should be serviced.
Flight Planning	GDL69 CONFIG – GDL 69 config error. Config service req'd.	GDL 69 configuration settings do not match those of backup configuration memory. The system should be serviced.
Procedures	GDL69 FAIL – GDL 69 has failed.	A fault has been detected in the GDL 69. The receiver is unavailable. The system should be serviced.
Hazard Avoidance	GDL88 ADS-B 1090 - ADS-B fault. 1090 receiver failure.	A failure has been detected in the 1090 receiver.
Additional Features	GDL88 ADS-B NO POS - GDL88 is not receiving position information.	The GDL 88 is not able to receive position information.
Abnormal Operation	GDL88 ADS-B NO TX - GDL88 Failure	Unable to transmit GDL 88 messages.
Annun/ Alerts	GDL88 ADS-B TRFC - GDL 88 ADS-B traffic has failed	The GDL 88 is incapable of processing traffic information.
	GDL88 ADS-B UAT - ADS-B fault. UAT receiver failure.	A failure has been detected in the UAT receiver.
Appendix	GDL88 ANTENNA - GDL 88 Antenna fault	The GDL 88 Antenna has failed.

Message	Comments
GDL88 CONFIG – GDL88 config error.	The GDL 88 and GDU have incompatible configurations. This alert is also set when the GDL 88 has an invalid mode S address configured or the mode S address does not match both XPDR mode S addresses.
GDL88 CSA FAIL -- ADS-B Airborne alerts failure.	GDL 88 ADS-B Conflict Situational Awareness (CSA) is unavailable.
GDL88 FAIL - Unable to transmit ADS-B messages.	The PFD has lost connection with the GDL 88.
GDL88 PRES ALT - GDL88 is not receiving pressure altitude.	The GDL 88 is not receiving pressure altitude data.
GDL88 SERVICE – GDL88 needs service.	Return unit for repair.
GDL88 XPDR - GDL88 not receiving XPDR code. Check XPDR mode.	The GDL 88 is not receiving transponder code. The transponder should be in ALT mode when airborne.
GEA1 CONFIG – GEA1 config error. Config service req'd.	The GEA1 configuration settings do not match those of backup configuration memory. The system should be serviced.
GEO LIMITS – AHRS1 too far North/South, no magnetic compass.	The aircraft is outside geographical limits for approved AHRS operation. Heading is flagged as invalid.
GEO LIMITS – AHRS2 too far North/South, no magnetic compass.	
GIA1 CONFIG – GIA1 config error. Config service req'd.	The GIA1 and/or GIA2 configuration settings do not match backup configuration memory. The system should be serviced.
GIA2 CONFIG – GIA2 config error. Config service req'd.	
GIA1 CONFIG – GIA1 audio config error. Config service req'd.	The GIA1 and/or GIA2 have an error in the audio configuration. The system should be serviced.
GIA2 CONFIG – GIA2 audio config error. Config service req'd.	

	Message	Comments
Flight Instruments	GIA1 COOLING – GIA1 temperature too low.	The GIA1 and/or GIA2 temperature is too low to operate correctly. Allow units to warm up to operating temperature.
EIS	GIA2 COOLING – GIA2 temperature too low.	
Nav/Com/XPDR/Audio	GIA1 COOLING – GIA1 over temperature.	The GIA1 and/or GIA2 temperature is too high. If problem persists, the system should be serviced.
AFCs	GIA2 COOLING – GIA2 over temperature.	
GPS Nav	GIA1 SERVICE – GIA1 needs service. Return the unit for repair.	The GIA1 and/or GIA2 self-test has detected a problem in the unit. The system should be serviced.
	GIA2 SERVICE – GIA2 needs service. Return the unit for repair.	
Flight Planning	GMA1 CONFIG – GMA1 config error. Config service req'd.	The audio panel configuration settings do not match backup configuration memory. The Perspective system should be serviced.
Procedures	GMA1 FAIL – GMA1 is inoperative.	The audio panel self-test has detected a fault. The audio panel is unavailable. The Perspective system should be serviced.
Hazard Avoidance	GMA1 SERVICE – GMA1 needs service. Return unit for repair.	The audio panel self-test has detected a problem in the unit. Certain audio functions may still be available, and the audio panel may still be usable. The Perspective system should be serviced when possible.
Additional Features	GMC CONFIG – GMC Config error. Config service req'd.	Error in the configuration of the GMC 705.
Abnormal Operation	GPS NAV LOST – Loss of GPS navigation. Insufficient satellites.	Loss of GPS navigation due to insufficient satellites.
Annun/Alerts	GPS NAV LOST – Loss of GPS navigation. Position error.	Loss of GPS navigation due to position error.
Appendix	GPS NAV LOST – Loss of GPS navigation. GPS fail.	Loss of GPS navigation due to GPS fault.

Message	Comments
GPS1 SERVICE – GPS1 needs service. Return unit for repair.	A fault has been detected in the GPS1 and/or GPS2 receiver. The receiver may still be available. The system should be serviced.
GPS2 SERVICE – GPS2 needs service. Return unit for repair.	
G/S1 FAIL – G/S1 is inoperative.	A fault has been detected in glideslope receiver 1 and/or receiver 2. The system should be serviced.
G/S2 FAIL – G/S2 is inoperative.	
G/S1 SERVICE – G/S1 needs service. Return unit for repair.	A fault has been detected in glideslope receiver 1 and/or receiver 2. The receiver may still be available. The system should be serviced when possible.
G/S2 SERVICE – G/S2 needs service. Return unit for repair.	
GSR1 FAIL – GSR1 has failed.	A fault has been detected in the GSR 56. The transceiver is unavailable. The Perspective system should be serviced.
GTS CONFIG – GTS Config error. Config service req'd.	The GTS and GDU have different copies of the GTS configuration, or the Mode S address is invalid. The Perspective system should be serviced.
HDG FAULT – AHRS1 magnetometer fault has occurred.	A fault has occurred in the #1 GMU 44. Heading is flagged as invalid. The AHRS uses GPS for backup mode operation. The Perspective system should be serviced.
HDG FAULT – AHRS2 magnetometer fault has occurred.	A fault has occurred in the #2 GMU 44. Heading is flagged as invalid. The AHRS uses GPS for backup mode operation. The Perspective system should be serviced.
HOLD EXPIRED – Holding EFC time expired.	Expect Further Clearance (EFC) time has expired for the User Defined Hold.
HW MISMATCH – GIA hardware mismatch. GIA1 communication halted.	A GIA mismatch has been detected, where only one is SBAS capable.
HW MISMATCH – GIA hardware mismatch. GIA2 communication halted.	
INSIDE ARSPC – Inside airspace.	The aircraft is inside the airspace.

- Flight Instruments
- EIS
- Nav/Com/XPDR/Audio
- AFCS
- GPS Nav
- Flight Planning
- Procedures
- Hazard Avoidance
- Additional Features
- Abnormal Operation
- Annun/Alerts
- Appendix
- Index

	Message	Comments
Flight Instruments	INVALID ADM – Invalid ADM: ATN communication halted.	Data link avionics were not configured correctly and therefore will not be able to communicate with the ground network.
EIS	LOCKED FPL – Cannot navigate locked flight plan.	This occurs when the pilot attempts to activate a stored flight plan that contains locked waypoint. Remove locked waypoint from flight plan. Update flight plan with current waypoint.
Nav/Com/XPDR/Audio	LOI – GPS integrity lost. Crosscheck with other NAVS.	GPS integrity is insufficient for the current phase of flight.
AFC	MANIFEST – COM1 software mismatch, communication halted.	COM1 and/or COM2 software mismatch. The system should be serviced.
GPS Nav	MANIFEST – COM2 software mismatch, communication halted.	
Flight Planning	MANIFEST – GCU software mismatch, communication halted.	The GCU 478 has incorrect software installed. The Perspective system should be serviced.
Procedures	MANIFEST – GDC1 software mismatch, communication halted.	The GDC 74A has incorrect software installed. The Perspective system should be serviced.
	MANIFEST – GDC2 software mismatch, communication halted.	
Hazard Avoidance	MANIFEST – GDL software mismatch, communication halted.	The GDL 69 has incorrect software installed. The system should be serviced.
Additional Features	MANIFEST – GDL software mismatch, communication halted.	The GDL 59 has incorrect software installed. The system should be serviced.
Abnormal Operation	MANIFEST – GEA1 software mismatch, communication halted.	The #1 GEA 71 has incorrect software installed. The system should be serviced.
Annun/Alerts	MANIFEST – GFC software mismatch, communication halted.	Incorrect servo software is installed, or gain settings are incorrect.
	MANIFEST – GIA1 software mismatch, communication halted.	The GIA1 and/or GIA 2 has incorrect software installed. The system should be serviced.
Appendix	MANIFEST – GIA2 software mismatch, communication halted.	
Index	MANIFEST – GMA1 software mismatch, communication halted.	The audio panel has incorrect software installed. The Perspective system should be serviced.

Message	Comments
MANIFEST – GMC software mismatch, communication halted.	The GMC 705 has incorrect software installed. The Perspective system should be serviced.
MANIFEST – GMU1 software mismatch, communication halted.	The GMU 44 has incorrect software installed. The Perspective system should be serviced.
MANIFEST – GMU2 software mismatch, communication halted.	
MANIFEST – GRS1 software mismatch, communication halted.	The #1 AHRS has incorrect software installed. The Perspective system should be serviced.
MANIFEST – GRS2 software mismatch, communication halted.	The #2 AHRS has incorrect software installed. The Perspective system should be serviced.
MANIFEST – GTS software mismatch, communication halted.	The GTS has incorrect software installed. The Perspective system should be serviced.
MANIFEST – GTX1 software mismatch, communication halted.	The transponder has incorrect software installed. The Perspective system should be serviced.
MANIFEST – NAV1 software mismatch, communication halted.	NAV1 and/or NAV2 software mismatch. The system should be serviced.
MANIFEST – NAV2 software mismatch, communication halted.	
MANIFEST – PFD1 software mismatch, communication halted.	The PFD and/or MFD has incorrect software installed. The system should be serviced.
MANIFEST – MFD1 software mismatch, communication halted.	
MFD1 CONFIG – MFD1 configuration error. Config service req'd.	The MFD configuration settings do not match backup configuration memory. The system should be serviced.
MFD1 COOLING – MFD1 has poor cooling. Reducing power usage.	The MFD is overheating and is reducing power consumption by dimming the display. If problem persists, the system should be serviced.
MFD1 DB ERR – MFD1 Airport Directory database error exists.	The MFD detected a fault in the Airport Directory database. Ensure the data card is properly inserted. Replace data card. If problem persists, the system should be serviced.

- Flight Instruments
- EIS
- Nav/Com/XPDR/Audio
- AFCS
- GPS Nav
- Flight Planning
- Procedures
- Hazard Avoidance
- Additional Features
- Abnormal Operation
- Annun/Alerts
- Appendix
- Index

	Message	Comments
Flight Instruments	MFD1 DB ERR – MFD1 basemap database error exists.	The MFD PFD detected a fault in the basemap database.
EIS	MFD1 DB ERR – MFD1 basemap database is incompatible.	The MFD detected a that the basemap database is incompatible.
Nav/Com/XPDR/Audio	MFD1 DB ERR – MFD1 navigation database error exists.	The MFD detected a fault in the navigation database. Attempt to reload the navigation database. If problem persists, the system should be serviced.
AFC	MFD1 DB ERR – MFD1 terrain database error exists.	The MFD detected a fault in the terrain database. Ensure that the terrain card is properly inserted in display. Replace terrain card. If problem persists, the system should be serviced.
GPS Nav	MFD1 DB ERR – MFD1 terrain database missing.	The terrain database is present on another LRU, but is missing on the specified LRU.
Flight Planning	MFD1 DB ERR – MFD1 obstacle database error exists.	The MFD detected a fault in the obstacle database. Ensure that the data card is properly inserted. Replace data card. If problem persists, the system should be serviced.
Procedures	MFD1 DB ERR – MFD1 obstacle database missing.	The obstacle database is present on another LRU, but is missing on the specified LRU.
Hazard Avoidance	MFD1 DB ERR – MFD1 Safe Taxi database error exists.	The MFD detected a fault in the Safe Taxi database. Ensure that the data card is properly inserted. Replace data card. If problem persists, the system should be serviced.
Additional Features	MFD1 DB ERR – MFD1 FliteCharts database error exists.	The MFD detected a fault in the FliteCharts database (optional feature). Ensure the data card is properly inserted. Replace data card. If problem persists, the system should be serviced.
Abnormal Operation	MFD1 DB ERR – MFD1 Chartview database error exists.	The MFD detected a fault in the ChartView database (optional feature). Ensure the data card is properly inserted. Replace data card. If the problem persists, the system should be serviced.
Annun/Alerts		
Appendix		

Message	Comments
MFD1 DB ERR – MFD1 multiple database errors exists.	The MFD detected a fault in more than one database. If problem persists, the system should be serviced.
MFD1 SERVICE – MFD1 needs service. Return unit for repair.	The MFD self-test has detected a problem. The system should be serviced.
MFD1 VOLTAGE – MFD1 has low voltage. Reducing power usage.	The MFD voltage is low. The system should be serviced.
NAV DB UPDATED – Active navigation database updated.	System has updated the active navigation database from the standby navigation database.
NAV1 SERVICE – NAV1 needs service. Return unit for repair.	A fault has been detected in the NAV1 and/or NAV2 receiver. The receiver may still be available. The system should be serviced.
NAV2 SERVICE – NAV2 needs service. Return unit for repair.	
NAV1 RMT XFR – NAV1 remote transfer key is stuck.	The remote NAV1 and/or NAV2 transfer switch is stuck in the enabled (or “pressed”) state. Press the transfer switch again to cycle its operation. If the problem persists, the system should be serviced.
NAV2 RMT XFR – NAV2 remote transfer key is stuck.	
NON-MAG UNITS – Non-magnetic NAV ANGLE display units are active.	Navigation angle is not set to MAGNETIC at power-up.
NON WGS84 WPT – Do not use GPS navigation to [xxxx].	The position of the selected waypoint [xxxx] is not calculated based on the WGS84 map reference datum and may be positioned in error as displayed. Do not use GPS to navigate to the selected non-WGS84 waypoint.
PFD1 DB ERR – PFD1 Airport Directory database error exists.	The PFD detected a fault in the Airport Directory database. Ensure the data card is properly inserted. Replace data card. If problem persists, the system should be serviced.
PFD1 DB ERR – PFD1 basemap database error exists.	The PFD detected a fault in the basemap database.
PFD1 DB ERR – PFD1 basemap database is incompatible.	The PFD detected a that the basemap database is incompatible.

- Flight Instruments
- EIS
- Nav/Com/XPDR/Audio
- AFCS
- GPS Nav
- Flight Planning
- Procedures
- Hazard Avoidance
- Additional Features
- Abnormal Operation
- Annun/Alerts
- Appendix
- Index

	Message	Comments
Flight Instruments	PFD1 DB ERR – PFD1 navigation database error exists.	The PFD detected a fault in the navigation database. Attempt to reload the navigation database. If problem persists, the system should be serviced.
EIS	PFD1 DB ERR – PFD1 terrain database error exists.	The PFD detected a fault in the terrain database. Ensure that the terrain card is properly inserted in display. Replace terrain card. If problem persists, the system should be serviced
Nav/Com/XPDR/Audio	PFD1 DB ERR – PFD1 terrain database missing.	The terrain database is present on another LRU, but is missing on the specified LRU.
AFC	PFD1 DB ERR – PFD1 obstacle database error exists.	The PFD detected a fault in the obstacle database. Ensure that the data card is properly inserted. Replace data card. If problem persists, the system should be serviced.
GPS Nav	PFD1 DB ERR – PFD1 obstacle database missing.	The obstacle database is present on another LRU, but is missing on the specified LRU
Flight Planning	PFD1 DB ERR – PFD1 Safe Taxi database error exists.	The MFD and/or PFD detected a fault in the Safe Taxi database. Ensure that the data card is properly inserted. Replace data card. If problem persists, the system should be serviced.
Procedures	PFD1 DB ERR – PFD1 multiple database errors exists.	The PFD detected a fault in more than one database. If problem persists, the system should be serviced.
Hazard Avoidance	PFD1 SERVICE – PFD1 needs service. Return unit for repair.	The PFD self-test has detected a problem. The system should be serviced.
Additional Features	PFD1 CONFIG – PFD1 configuration error. Config service req'd.	The PFD configuration settings do not match backup configuration memory. The system should be serviced.
Abnormal Operation	PFD1 COOLING – PFD1 has poor cooling. Reducing power usage.	The PFD is overheating and is reducing power consumption by dimming the display. If problem persists, the system should be serviced.
Annun/Alerts		
Appendix		
Index		

Message	Comments
PFD1 KEYSTK – PFD1 [keyname] Key is stuck.	A key is stuck on the PFD and/or MFD bezel. Attempt to free the stuck key by pressing it several times. The system should be serviced if the problem persists.
MFD1 KEYSTK – MFD [keyname] Key is stuck.	
PFD1 VOLTAGE – PFD1 has low voltage. Reducing power usage.	The PFD1 voltage is low. The system should be serviced.
[PFD1, or MFD1] CARD 1 REM – Card 1 was removed. Reinsert card.	The SD card was removed from the top card slot of the PFD or MFD. The SD card needs to be reinserted.
[PFD1, or MFD1] CARD 2 REM – Card 2 was removed. Reinsert card.	The SD card was removed from the bottom card slot of the PFD or MFD. The SD card needs to be reinserted.
[PFD1, or MFD1] CARD 1 ERR – Card 1 is invalid.	The SD card in the top card slot of the PFD or MFD contains invalid data.
[PFD1, or MFD1] CARD 2 ERR – Card 2 is invalid.	The SD card in the bottom card slot of the specified PFD or MFD contains invalid data.
PTK FAIL – Parallel track unavailable: bad geometry.	Bad parallel track geometry.
PTK FAIL – Parallel track unavailable: invalid leg type.	Invalid leg type for parallel offset.
PTK FAIL – Parallel track unavailable: past IAF.	IAF waypoint for parallel offset has been passed.
REGISTER CONNEXT – Data services are inoperative, register w/ Connex.	The GDL 59 is not registered with Garmin Connex or its current registration data has failed authentication.
SCHEDULER [#] – <message>.	Message criteria entered by the user.
SLCT FREQ – Select appropriate frequency for approach.	The system notifies the pilot to load the approach frequency for the appropriate NAV receiver. Select the correct frequency for the approach.
SLCT NAV – Select NAV on CDI for approach.	The system notifies the pilot to set the CDI to the correct NAV receiver. Set the CDI to the correct NAV receiver.
STEEP TURN – Steep turn ahead.	A steep turn is 15 seconds ahead. Prepare to turn.

- Flight Instruments
- EIS
- Nav/Com/XPDR/Audio
- AFCS
- GPS Nav
- Flight Planning
- Procedures
- Hazard Avoidance
- Additional Features
- Abnormal Operation
- Annun/Alerts
- Appendix
- Index

	Message	Comments
Flight Instruments	STRMSCP FAIL – Stormscope has failed.	Stormscope has failed. The system should be serviced.
EIS	SVT DISABLED - Out of available terrain region.	Synthetic Vision is disabled because the aircraft is not within the boundaries of the installed terrain database.
Nav/Com/XPDR/Audio	SVT DISABLED – Terrain DB resolution too low.	Synthetic Vision is disabled because a terrain database of sufficient resolution (9 arc-second or better) is not currently installed.
AFC	SW MISMATCH – GDU software version mismatch. Xtalk is off.	The MFD and PFD have different software versions installed. The system should be serviced.
GPS Nav	TERRAIN AUD CFG – Trn Awareness audio config error. Service req'd.	Terrain audio alerts are not configured properly. The system should be serviced
Flight Planning	TERRAIN DSP – [PFD1 or MFD1] Terrain awareness display unavailable.	One of the terrain, airport terrain, or obstacle databases required for TAWS in the PFD or MFD is missing or invalid.
Procedures	TIMER EXPIRD – Timer has expired.	The system notifies the pilot that the timer has expired.
Hazard Avoidance	TRAFFIC FAIL – Traffic device has failed.	The system is no longer receiving data from the traffic system. The traffic device should be serviced.
Additional Features	TRN AUD FAIL – Trn Awareness audio source unavailable.	The audio source for terrain awareness is offline. Check GIA1 or GIA 2.
Abnormal Operation	UNABLE V WPT – Can't reach current vertical waypoint.	The current vertical waypoint can not be reached within the maximum flight path angle and vertical speed constraints. The system automatically transitions to the next vertical waypoint.
Annun/ Alerts	VNV – Unavailable. Unsupported leg type in flight plan.	The lateral flight plan contains a procedure turn, vector, or other unsupported leg type prior to the active vertical waypoint. This prevents vertical guidance to the active vertical waypoint.
Appendix	VNV – Unavailable. Excessive crosstrack error.	The current crosstrack exceeds the limit, causing vertical deviation to go invalid.
Index	VNV – Unavailable. Excessive track angle error.	The current track angle error exceeds the limit, causing the vertical deviation to go invalid.

Message	Comments
VNV – Unavailable. Parallel course selected.	A parallel course has been selected, causing the vertical deviation to go invalid.
WPT ARRIVAL – Arriving at waypoint -[xxxx]	Arriving at waypoint [xxxx], where [xxxx] is the waypoint name.
XPDR1 ADS-B FAIL – XPDR1 unable to transmit ADS-B messages.	ADS-B is inoperative. Other transponder functions may be available. Transponder should be serviced when possible. (GTX 33 with Extended Squitter only.)
XPDR1 CONFIG – XPDR1 config error. Config service req'd.	The transponder configuration settings do not match those of backup configuration memory or the Mode S address is invalid. The Perspective system should be serviced.
XPDR1 FAIL – XPDR1 is inoperative.	There is no communication with the #1 transponder.
XPDR1 SRVC – XPDR1 needs service. Return unit for repair.	The #1 transponder should be serviced when possible.
XTALK ERROR – A flight display crosstalk error has occurred.	The MFD and PFD are not communicating with each other. The system should be serviced.

FLIGHT PLAN IMPORT/EXPORT MESSAGES

In some circumstances, some messages may appear in conjunction with others.

Flight Plan Import/Export Results	Description
'Flight plan successfully imported.'	A flight plan file stored on the SD card was successfully imported as a stored flight plan.
'File contained user waypoints only. User waypoints imported successfully. No stored flight plan data was modified.'	The file stored on the SD card did not contain a flight plan, only user waypoints. These waypoints have been saved to the system user waypoints. No flight plans stored in the system have been modified.
'No flight plan files found to import.'	The SD card contains no flight plan data.
'Flight plan import failed.'	Flight plan data was not successfully imported from the SD card.

	Flight Plan Import/Export Results	Description
Flight Instruments	'Flight plan partially imported.'	Some flight plan waypoints were successfully imported from the SD card, however others had errors and were not imported. A partial stored flight plan now exists in the system.
EIS	'File contained user waypoints only.'	The file stored on the SD card did not contain a flight plan, only user waypoints. One or more of these waypoints did not import successfully.
Nav/Com/XPDR/Audio	'Too many points. Flight plan truncated.'	The flight plan on the SD card contains more waypoints than the system can support. The flight plan was imported with as many waypoints as possible.
AFCs	'Some waypoints not loaded. Waypoints locked.'	The flight plan on the SD card contains one or more waypoints that the system cannot find in the navigation database. The flight plan has been imported, but must be edited within the system before it can be activated for use.
GPS Nav	'User waypoint database full. Not all loaded.'	The flight plan file on the SD card contains user waypoints. The quantity of stored user waypoints has exceeded system capacity, therefore not all the user waypoints on the SD card have been imported. Any flight plan user waypoints that were not imported are locked in the flight plan. The flight plan must be edited within the system before it can be activated for use.
Flight Planning	'One or more user waypoints renamed.'	One or more imported user waypoints were renamed when imported due to naming conflicts with waypoints already existing in the system.
Procedures	'Flight plan successfully exported.'	The stored flight plan was successfully exported to the SD card.
Hazard Avoidance	'Flight plan export failed.'	The stored flight plan was not successfully exported to the SD card. The SD card may not have sufficient available memory or the card may have been removed prematurely.
Additional Features		
Abnormal Operation		
Annun/Alerts		

PILOT PROFILE IMPORT/EXPORT MESSAGES

	Pilot Profile Import/Export Results	Description
Index	'No pilot profile plan files found to import.'	Displayed if the SD card does not have one or more valid pilot profile filenames.

Pilot Profile Import/Export Results	Description
'Overwrite existing profile?'	Displayed if the profile name matches the name of existing profile.
'Profile name invalid. Enter a different profile name.'	Displayed if the profile name is invalid.
'All available pilot profiles in use. Delete a profile before importing another.'	Displayed if the maximum number for pilot profiles has been reached.
'Pilot profile import failed.'	Displayed if the importing operation fails for any other reason.
'Pilot profile import succeeded.'	Displayed if the importing operation succeeds.
'Overwrite existing file?'	Displayed if the filename matches the name of an existing file on the SD card.
'Pilot profile export failed.'	Displayed if the export operation fails.
'Pilot profile export succeeded.'	Displayed if the export operation succeeds.

ADS-B STATUS PAGE MESSAGES

ADS-B Status Page Item	Status Message	
Traffic Application Status: AIRBORNE (AIRB), SURFACE (SURF), AIRBORNE ALERTS (CSA)	ON	Traffic application is currently on. Required input data is available, and it meets performance requirements.
	AVAILABLE TO RUN	Traffic application is not currently active, but application is ready to run when condition(s) determine the application should be active. Required input data is available, and it meets performance requirements.
	NOT AVAILABLE	Traffic application is not available. Required input data is available, but it does not meet performance requirements.
	FAULT	Traffic application is not available. Required input data is not available or the application has failed.
	NOT CONFIGURED	Traffic application is not available, because it has not been configured. If this annunciation persists, the system should be serviced.
	-----	Traffic application status is invalid or unknown.

- Flight Instruments
- EIS
- Nav/Com/XPDR/Audio
- AFCS
- GPS Nav
- Flight Planning
- Procedures
- Hazard Avoidance
- Additional Features
- Abnormal Operation
- Annun/Alerts
- Appendix
- Index

- Flight Instruments
- EIS
- Nav/Com/XPDR/Audio
- AFCs
- GPS Nav
- Flight Planning
- Procedures
- Hazard Avoidance
- Additional Features
- Abnormal Operation
- Annun/Alerts
- Appendix
- Index

ADS-B Status Page Item	Status Message	
TIS-B/ADS-R Coverage	AVAILABLE	The system is receiving the ADS-R coverage from an FAA ground station.
	NOT AVAILABLE	The system is not receiving the ADS-R coverage from an FAA ground station.
	-----	ADS-R coverage is invalid or unknown.
GPS Status: GPS Source	External #1	The GDL 88 is using the #1 GPS receiver for the GPS position source.
	External #2	The GDL 88 is using the #2 GPS receiver for the GPS position source.
	-----	The GPS source is invalid or unknown.
Ground Uplink Status: Last uplink	Number of minutes, or '-----'	Displays the number of minutes since the last uplink from a ground station occurred. If no uplink has been received, or the status is invalid, dashes appear instead of a number of minutes.
FIS-B Weather Status: FIS-B Processing	ENABLED	The FIS-B weather feature is enabled to process and display FIS-B weather products.
	DISABLED	The FIS-B weather feature is disabled.
	-----	No data received from the GDL 88 UAT.
Weather Products: AIRMET CONUS NEXRAD METAR METAR GRAPHICAL NOTAM/TFR PIREP REGIONAL NEXRAD SIGMET TAF WINDS/TEMPS ALOFT	AVAILABLE	FIS-B weather data is available for display for the weather product.
	NOT AVAILABLE	FIS-B weather data is not available for the weather product, and/or the system is not receiving the FIS-B weather service.
	AWAITING DATA	The system is receiving the FIS-B weather service, and is waiting to receive the weather product from the FIS-B data broadcast.

APPENDIX

PFD SOFTKEY MAP

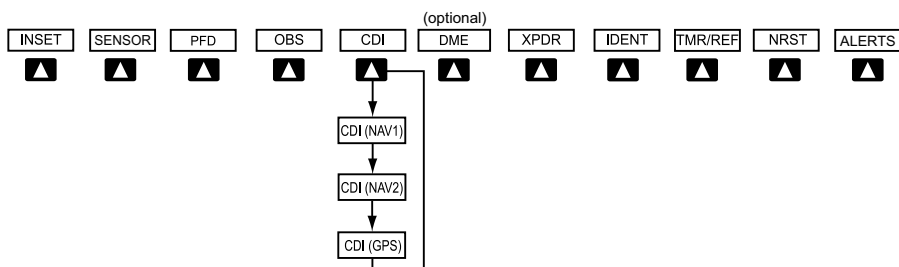

Top Level PFD Softkeys

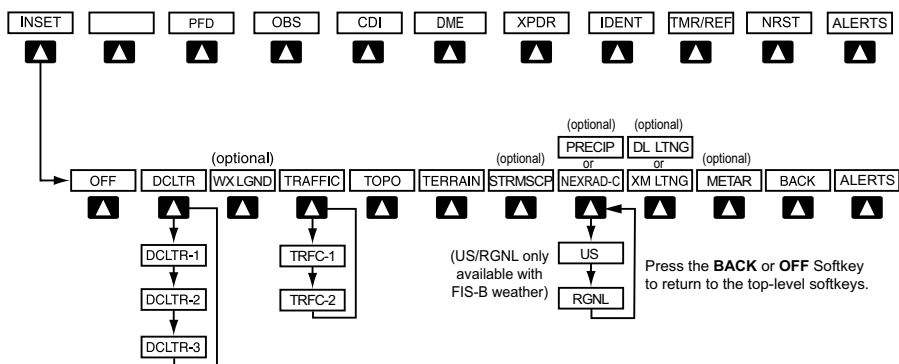

Inset Map Softkeys

Level 1	Level 2	Description
INSET		Displays Inset Map in PFD lower left corner
	OFF	Removes Inset Map
	DCLTR (3)	Selects desired amount of map detail; cycles through declutter levels: DCLTR (No Declutter): All map features visible DCLTR-1: Declutters land data DCLTR-2: Declutters land and SUA data DCLTR-3: Removes everything except the active flight plan

Level 1	Level 2	Description
	WX LGND	Displays icon and age on the Inset Map for the selected weather products (optional)
	TRAFFIC	Cycles through traffic display options: TRFC-1: Traffic displayed on inset map TRFC-2: Traffic Map Page is displayed in the inset map window
	TOPO	Displays topographical data (e.g., coastlines, terrain, rivers, lakes) and elevation scale on Inset Map
	TERRAIN	Displays terrain information on Inset Map
	STRMSCP	Press to display the Stormscope lightning data on the Inset Map (within a 200 nm radius of the aircraft)
	NEXRAD-C	Displays SiriusXM NEXRAD-C weather and coverage on Inset Map (optional) When the GDL 88 is installed and FIS-B is the selected weather source, softkey cycles through NEXRAD-C coverage options on Inset Map (optional): US: Continental US NEXRAD-C weather displayed on Inset Map RGNL: Regional NEXRAD-C weather displayed on Inset Map
	PRECIP	Displays/removes Garmin Connex radar precipitation and radar coverage information on Inset Map (optional)

Level 1	Level 2	Description
	XM LTNG or DL LTNG	Displays XM lightning information on the Inset Map (optional)
	METAR	Displays METAR flags for the airport symbols on the Inset Map



Press the **BACK** Softkey to return to the top level softkeys.

Sensor Softkeys

Level 1	Level 2	Description
SENSOR		Displays softkeys for selecting the #1 and #2 AHRS and Air Data Computers (only available when optional ADC2 and AHRS2 are installed)
	ADC1	Selects the #1 Air Data Computer
	ADC2	Selects the optional #2 Air Data Computer
	AHRS1	Selects the #1 AHRS
	AHRS2	Selects the optional #2 AHRS

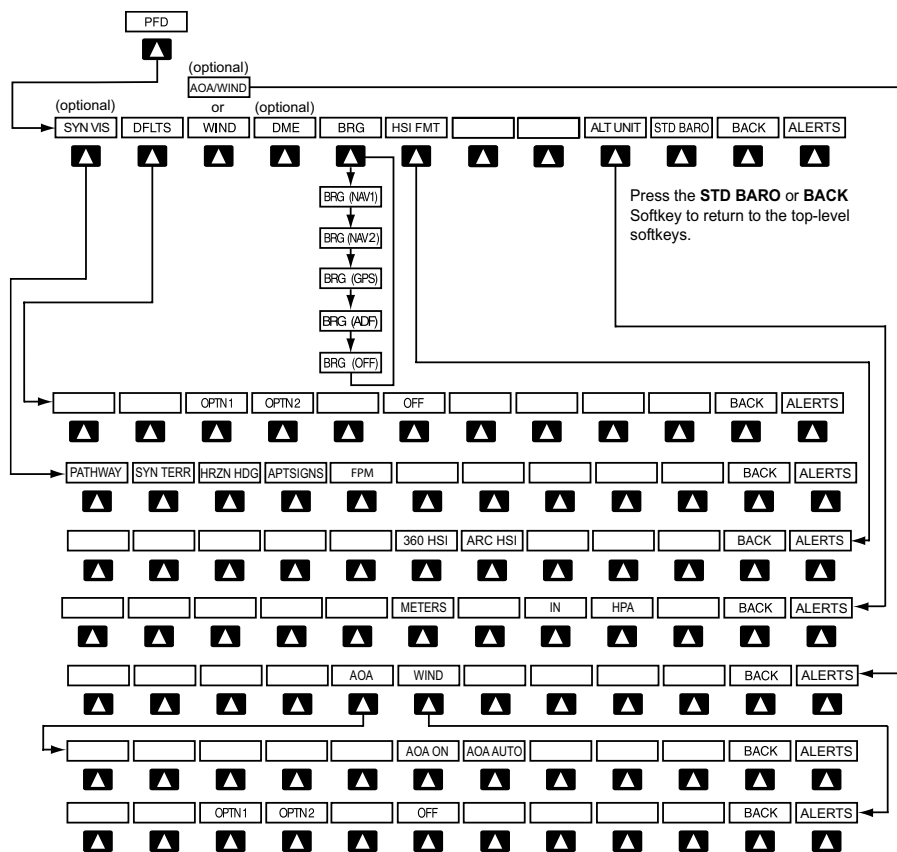

PFD Configuration Softkeys

Level 1	Level 2	Level 3	Level 4	Description
PFD				Displays second-level softkeys for additional PFD configurations
	SYN VIS			Displays the softkeys for enabling or disabling Synthetic Vision features
		PATHWAY		Displays rectangular boxes representing the horizontal and vertical flight path of the active flight plan
		SYN TERR		Enables synthetic terrain depiction
		HRZN HDG		Displays compass heading along the Zero-Pitch line
		APTSIGNS		Displays position markers for airports within approximately 15 nm of the current aircraft position. Airport identifiers are displayed when the airport is within approximately 9 nm.
		FPM		Enables the Flight Path Marker when SVT is disabled. HRZN HDG must be enabled.
	DFLT5			Resets PFD to default settings, including changing units to standard
AOA and Wind Softkeys shown if optional Angle of Attack Sensor is installed:				
	AOA/WIND			Displays the second-level softkeys for displaying Angle of Attack (AOA) Indicator and wind information.
		AOA		Shows softkeys for controlling the display of the AOA Indicator (optional).

- Flight Instruments
- EIS
- Nav/Com/XPDR/Audio
- AFC5
- GPS Nav
- Flight Planning
- Procedures
- Hazard Avoidance
- Additional Features
- Abnormal Operation
- Annun/Alerts
- Appendix
- Index

Level 1	Level 2	Level 3	Level 4	Description
			AOA ON	Enables/disables the display of the AOA Indicator on the PFD.
			AOA AUTO	When selected, AOA Indicator automatically appears when the AOA is greater than 0.2, or the flaps are extended.
		WIND		Displays softkeys to select wind data parameters
			OPTN 1	Wind direction arrow with direction and speed
			OPTN 2	Wind direction arrows with headwind and crosswind components
			OFF	Information not displayed
Wind Softkeys shown without Angle of Attack Sensor installed:				
	WIND			Displays the second-level softkeys for displaying wind information.
		OPTN 1		Wind direction arrow with direction and speed
		OPTN 2		Wind direction arrows with headwind and crosswind components
		OFF		Wind information not displayed
	DME			Select to display the DME information window (optional)

Level 1	Level 2	Level 3	Level 4	Description
	BRG			Cycles the Bearing Information Window through NAV1, NAV2 (omitted if BRG2 installed) or GPS/waypoint identifier and GPS-derived distance information, and ADF. All Bearing labels will be labeled BRG1 if BRG2 is installed.
	HSI FRMT			Displays the HSI formatting softkeys
		360 HSI		Displays the HSI in a 360 degree format
		ARC HSI		Displays the HSI in an arc format
	ALT UNIT			Displays softkeys for setting the altimeter and BARO settings to metric units
		METERS		When enabled, displays altimeter in meters
		IN		Select to display the BARO setting as inches of mercury
		HPA		Select to display the BARO setting as hectopascals
	STD BARO			Sets altimeter setting to standard barometric pressure

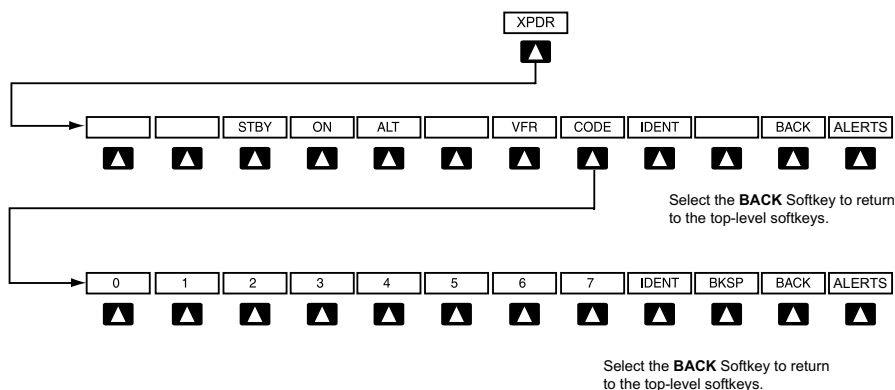

Transponder Softkeys

Level 1	Level 2	Level 3	Description
XPDR			Displays transponder mode selection softkeys
	STBY		Selects Standby Mode (transponder does not reply to any interrogations)
	ON		Selects Mode A (transponder replies to interrogations)
	ALT		Selects Mode C – Altitude Reporting Mode (transponder replies to identification and altitude interrogations)
	VFR		Automatically enters the VFR code (1200 in the U.S.A. only)
	CODE		Displays transponder code selection softkeys 0-7
		0 — 7	Use numbers to enter code
		BKSP	Removes numbers entered, one at a time
IDENT			Activates the Special Position Identification (SPI) pulse for 18 seconds, identifying the transponder return on the ATC screen
TMR/REF			Displays Timer/References Window
NRST			Displays Nearest Airports Window
ALERTS			Displays the Alerts Window

MFD SOFTKEY MAP

MFD softkeys vary depending on the page selected. EIS and Navigation Map Page (default MFD page) softkeys are described here.



NOTE: The ice protection system (optional) must be operated in accordance with the approved flight manual limitations. This option is only available on SR22 and SR22T models.

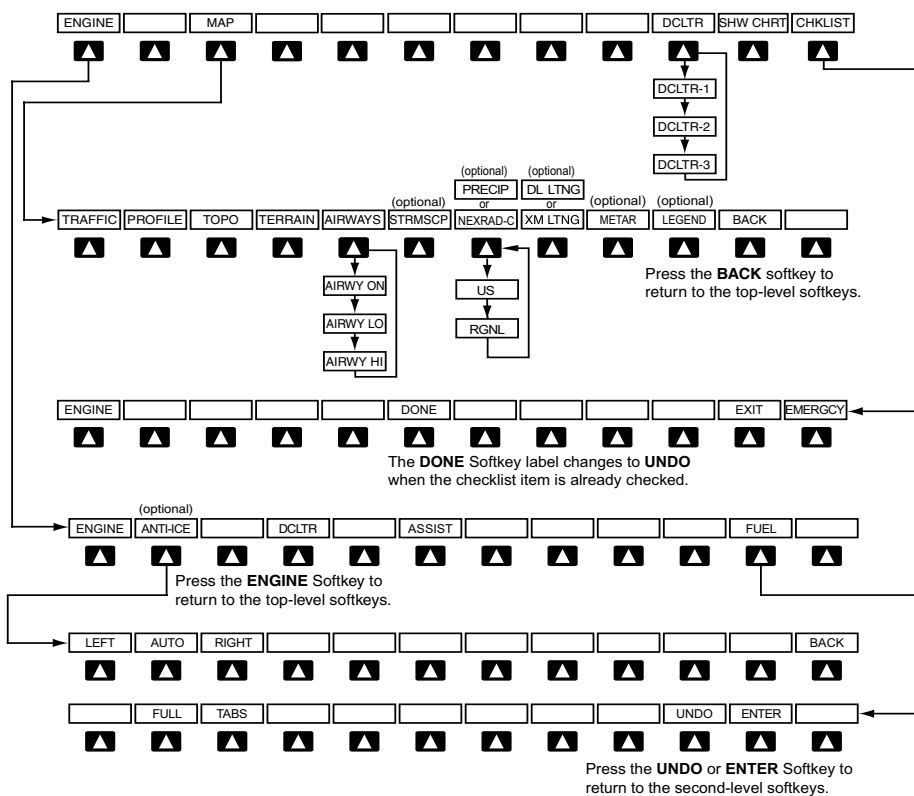

MFD Softkeys

	Level 1	Level 2	Level 3	Description
Flight Instruments	ENGINE			Displays full Engine Page and second-level engine softkeys; press again to return to the Engine Strip and top-level softkeys
EIS		ANTI-ICE		Displays Anti-ice softkeys (optional-FIKI only)
Nav/Com/XPDR/Audio			LEFT	Selects manual mode and opens the left tank valve and closes the right tank valve
AFCs			AUTO	Selects Auto Tank Mode
			RIGHT	Selects manual mode and opens the right tank valve and closes the left tank valve
GPS Nav		DCLTR		Declutters the Engine Temperatures Box removing bars and temperatures readouts
Flight Planning		ASSIST		Identifies temperature peaks
		FUEL		Accesses the Initial Usable Fuel Page
Procedures			FULL	Resets fuel totalizer to full (<i>usable fuel</i>)
			TABS	Resets fuel totalizer to tabs (<i>usable fuel</i>)
			UNDO	Rejects the last entry and resets to the previous entry
Hazard Avoidance			ENTER	Saves the usable fuel amount shown on the Initial Usable Fuel Page
Additional Features	MAP			Enables second-level Navigation Map softkeys
Abnormal Operation		TRAFFIC		Displays traffic information on Navigation Map
Annun/Alerts		PROFILE		Displays/removes Profile View on Navigation Map Page
Appendix		TOPO		Displays topographical data (e.g., coastlines, terrain, rivers, lakes) and elevation scale on Navigation Map
Index		TERRAIN		Displays terrain information on Navigation Map

Level 1	Level 2	Level 3	Description
	LEGEND		Displays the legend for the selected weather products. Available only when NEXRAD, XM LTNG, and/or METAR softkeys are selected.
	BACK		Returns to top-level softkeys
DCLTR (3)			Selects desired amount of map detail; cycles through declutter levels: DCLTR (No Declutter): All map features visible DCLTR-1: Declutters land data DCLTR-2: Declutters land and SUA data DCLTR-3: Removes everything except the active flight plan
SHW CHRT			When available, displays optional airport and terminal procedure charts
CHKLIST			When available, displays optional checklists
	DONE		Selects the highlighted checklist item
	EXIT		Returns to the top-level softkeys
	EMERGCY		Immediately accesses the emergency procedures

LOADING UPDATED DATABASES



CAUTION: Never disconnect power to the system when loading a database. Power interruption during the database loading process could result in maintenance being required to reboot the system.



CAUTION: When downloading updates to the Jeppesen Navigation Database, copy the data to an SD card other than a Garmin Supplemental Data Card. Otherwise, data corruption can occur.



NOTE: When loading database updates, the 'DB Mismatch' message will be displayed until database synchronization is complete, followed by turning system power off, then on. Synchronization can be monitored on the AUX-SYSTEM STATUS Page.



NOTE: Loading a database in the system prior to its effective date will result in the expiration date on the Power-Up Page and the effective date on the AUX-System Status Page being displayed in amber.

In some cases it may be necessary to obtain an unlock code from Garmin in order to make the database product functional. It may also be necessary to have the system configured by a Garmin authorized service facility in order to use some database features.

If an error occurs during synchronization, an error message will be displayed, followed by the affected display in the Sync Status section of the Database Window. If synchronization completes on one display, but an error occurs on another, the error message will be displayed with the affected displays listed after it. When an error message is displayed, the problem must be corrected before synchronization can be completed. A power cycle is required to restart synchronization when 'Card Full' or 'Err' is shown.

Jeppesen Databases

Updating the active Jeppesen navigation database (not using the Dual Navigation Database or Automatic Database Synchronization Features):

- 1) With the system OFF, insert the SD card containing the new navigation database version into the top card slot of the display (PFD1 or MFD) to be updated (label

of SD card facing left).

- 2) Apply power to the system. A prompt will appear in the upper left corner of the display:
- 3) Press the **NO** Softkey to proceed to loading the active database.
- 4) Press the **YES** Softkey to update the active navigation database.
- 5) After the update completes, the display starts in normal mode. Do not remove power while the display is starting.
- 6) Turn the system OFF and remove the SD card from the top card slot.
- 7) Repeat steps 1 through 6 for the other display (PFD1 or MFD). Remove the SD card when finished.
- 8) Apply power to the system and press the **ENT** Key to acknowledge the Power-Up Page.
- 9) Turn the large **FMS** Knob to select the AUX Page group on the MFD.
- 10) Turn the small **FMS** Knob to select the System Status Page.
- 11) Press the Display Database Selection Softkey to show active navigation database information for each display (**MFD1 DB**, **PFD1 DB**). Verify the correct active navigation database cycle information is shown for each display.

Dual Navigation Database Feature

Loading a standby navigation database:

- 1) With the system OFF, insert the SD card containing the new navigation database version into the top card slot of the MFD.
- 2) Verify that an SD card is inserted in the bottom slot of the PFD.
- 3) Apply power to the system. A prompt is displayed.
- 4) Press the **YES** Softkey. The navigation database is copied to the SD card in the bottom card slot of the MFD.
- 5) After the navigation database files are copied to the bottom SD card.
- 6) As instructed on the display, press any key to continue.
- 7) Press any key to continue.
- 8) Press the **NO** Softkey. The display now starts in normal mode. Since the database effective date is not yet valid, it should not be loaded as the active database. The display now starts in normal mode. Do not remove power while the display is starting.
- 9) Press the **ENT** Key to acknowledge the Power-Up Page.

- 10) Turn the large **FMS** Knob to select the AUX Page group on the MFD.
- 11) Turn the small **FMS** Knob to select the System Status Page.
- 12) The new database is copied to the SD card in the bottom card slot of the PFD. Progress can be monitored in the SYNC STATUS field. When copying is finished, 'Complete' is displayed.
- 13) Remove power from the system.
- 14) Remove the SD card from the top card slot of the MFD.
- 15) Apply power to the system.
- 16) Press the **ENT** Key to acknowledge the Power-Up Page.
- 17) Turn the large **FMS** Knob to select the AUX Page group on the MFD.
- 18) Turn the small **FMS** Knob to select the System Status Page.
- 19) Press the Display Database Selection Softkey to show standby navigation database information for each display (**MFD1 DB, PFD1 DB**). Verify the correct standby navigation database cycle information is shown for each display.

Manually activating the standby navigation database:

- 1) From the AUX-SYSTEM STATUS Page, select the **STANDBY DB** Softkey.
- 2) A prompt is displayed, select 'Yes' to overwrite the Active Navigation Database with the Standby Navigation Database. Select 'No' to cancel.
- 3) Remove power from the system.
- 4) Apply power to the system.
- 5) Press the **ENT** Key to acknowledge the Power-Up Page.
- 6) Turn the large **FMS** Knob to select the AUX Page group on the MFD.
- 7) Turn the small **FMS** Knob to select the System Status Page.
- 8) Select the Display Database Selection Softkey to show navigation database information for each display (MFD1 DB, PFD1 DB). Verify the correct navigation database cycle information is shown for each display.

Garmin Databases

The automatic database synchronization feature automatically transfers a database from one Supplemental Data Card to the other Supplemental Data Card to ensure that all databases are synchronized throughout the system. After power-up, the system compares all copies of each applicable database. If similar databases do not match, the most recent valid database is automatically copied to each card in the system that does not already contain that database.

Error Message	Description
Canceled	Database synchronization has been canceled by removing the bottom SD card in display being updated
Card Full	SD card does not contain sufficient memory
Err	Displayed for all other errors that may cause the synchronization process to be halted
Timeout	System timed-out prior to the database transfer completing

Database Synchronization Error Messages

Updating Basemap, SafeTaxi, Obstacle, and Airport Directory Databases:

- 1) With system power OFF, remove the MFD database card from the bottom card slot of the MFD.
- 2) Update the basemap, SafeTaxi, obstacle and/or airport directory databases on the MFD card.
- 3) Insert the MFD database card into the bottom card slot of the MFD.
- 4) Apply power to the system, check that the databases are initialized and displayed on the Power-Up Page. If a 'Verifying' message is seen, wait for the system to finish loading before proceeding to step 5.
- 5) Acknowledge the Power-up Page agreement by pressing the **ENT** Key or the right most softkey.
- 6) Turn the large **FMS** Knob to select the AUX Page group on the MFD.
- 7) Turn the small **FMS** Knob to select the System Status Page.
- 8) Monitor the Sync Status in the Database Window. Wait for all databases to complete synchronization, indicated by 'Complete' being displayed.
- 9) Remove and reapply power to the system.
- 10) Turn the large **FMS** Knob to select the AUX Page group on the MFD.
- 11) Turn the small **FMS** Knob to select the System Status Page.
- 12) Press the Display Database Selection Softkey to show database information for each display (**MFD1 DB, PFD1 DB**). Verify the correct database cycle information is shown for each database for each display.

Updating Terrain, FliteCharts, and ChartView Databases:

- 1) With system power OFF, remove the Supplemental Data Card from the bottom card slot of the MFD and both PFDs.
- 2) Copy the updated terrain database to both Supplemental Data Cards. Copy the updated FliteCharts or ChartView database to one Supplemental Data Card.
- 3) Insert the updated Supplemental Data Cards into the bottom card slot of the MFD and PFDs. The Supplemental Data Card containing the FliteCharts or ChartView database is inserted in the MFD.
- 4) Apply power to the system, check that the databases are initialized and displayed on the Power-Up Page. A 'Verifying' message may be seen. If this message is present, wait for the system to finish loading before proceeding to step 5.
- 5) Acknowledge the Power-up Page agreement by pressing the **ENT** Key or the right most softkey.
- 6) Turn the large **FMS** Knob to select the AUX Page group on the MFD.
- 7) Turn the small **FMS** Knob to select the System Status Page.
- 8) Press the Display Database Selection Softkey to show database information for each display (**MFD1 DB**, **PFD1 DB**, or **PFD2 DB**). Verify the correct database cycle information is shown for each database for each display.
- 9) Remove power from the system.

Magnetic Field Variation Database Update

At startup, the system compares this version of the MV DB with that presently being used by the AHRS (GRS). If the system determines the MV DB needs to be updated, a prompt is displayed on the Navigation Map Page.

Loading the magnetic field variation database update:

- 1) With 'OK' highlighted, as shown in the previous figure, press the **ENT** Key on the MFD. A progress monitor is displayed as shown in the following figure.
- 2) If a single GRS is installed, the system is ready for use when the upload is complete. Otherwise, continue the procedure to update the other GRS.
- 3) The system displays a prompt for the next GRS upload is displayed.
- 4) With 'OK' highlighted, press the **ENT** Key on the MFD. A progress monitor is displayed. When the upload is complete, the system is ready for use.

- Flight Instruments
- EIS
- Nav/Com/XPDR/Audio
- AFCs
- GPS Nav
- Flight Planning
- Procedures
- Hazard Avoidance
- Additional Features
- Abnormal Operation
- Annun/Alerts
- Appendix**
- Index

Blank Page

Symbols

3D Audio 24

A

Access code 67
 Activate a flight plan 30
 Active Channel 102
 Active Database 186
 AC-U-KWIK Airport Directory 101
 ADF 15, 16
 Advisory alerts 145
 AHRS 153, 154, 159, 161
 Airport Directory 101
 Airport Signs 97
 Airways 183
 Altimeter setting 1, 133
 Anti-ice 12
 AOPA Airport Directory 101
 Assist, engine leaning 11–13
 Audio panel controls
 NAV1, NAV2 16
 Automatic Descent Mode 28, 121

B

Barometric Altitude Minimums 3
 Blue-Select Mode 23
 Bluetooth 128, 129

C

Caution alerts 141
 CDI 1, 16, 167
 Cell 61, 62
 Cell mode 62
 Channel Presets 103
 ChartView 99, 100
 Checklists 119–120
 CLD TOP Softkey 74

Clearance player 24
 Clearance Recorder 24
 Code selection softkeys 15
 COM 15, 16, 24, 132

D

Database Synchronization 185, 188
 DB Mismatch 185
 Dead Reckoning 134
 Declutter 133, 173, 184
 Designated altitudes 33
 Direct-to 29
 DME 15, 16
 DR mode 134, 135

E

Edit a flight plan 50
 Electronic checklists 120, 121
 Electronic Stability and Protection 122
 Emergency checklist 120
 Enable Terrain 94
 Enhanced Vision System 98
 ESP™ 122
 EVS 98, 99
 Exhaust Gas Temperature (EGT) 11–12

F

Flight Director 25
 Flight ID 87
 Flight Information Service-Broadcast
 (FIS-B) 172
 Flight path marker 97
 Flight plan import/export messages 169
 Flight Stream 128
 FliteCharts® 99, 100
 Frequency Transfer 16
 Fuel 7, 9, 11, 131, 182

Fuel calculations 9, 131

Fuel flow 9

Fuel Quantity 5, 6, 9

Fuel totalizer 9, 182

G

Garmin Pilot 128

H

Horizon heading 97

Hypoxia Detection 121

I

Inhibit 93, 96

Inhibit TAWS 96

Inhibit Terrain 93

Insertion Point Indicator 31, 44, 45,
46, 52

Inset Map 173, 174

Intercom isolation 17

IOI 147, 149, 150

Iridium 103, 104

Iridium satellite network 104

J

Jeppesen 100

L

Lightning 61, 62, 174

M

Magnetic Field Variation Database
Update 189

Map panning 64

Message advisories 152

Messages window 119

METAR 64

Minimums 151

MISCOMP 144

Index-2

MKR/MUTE 24

Mode selection softkeys 15

Multi Function Display (MFD)
Softkeys 181

N

NAV 16

NAV1 1, 16

NAV2 1, 16

Navigation database 31, 33

Network 116, 117

NEXRAD 63, 183

NEXRAD Softkey 73

O

OBS 1

Obstacles 156, 161

P

Pairing 128

Pathways 97

Pilot Profile 124

Pilot Profile Import/Export Messages
170

PIREP 77

PIT 144

Power-up page 119

Predefined message 111

Profile View 63, 92, 94, 96, 182

Q

Quick Select Box 30, 31, 42, 44, 45, 46,
49, 50, 55, 56

R

Register 67

Reversionary mode 131

ROC 147, 149, 150

S

- SafeTaxi® 99
- SBAS 57, 94, 95, 134, 135, 161
- Scheduler 118
- Secure Digital (SD) card 119
- Sensor 144
- SiriusXM lightning 175, 183
- SiriusXM radio entertainment 22
- SiriusXM weather 63
- SiriusXM Weather 63
- SMS 103
- Split COM operation 16, 17
- Standby Navigation Database 186, 187
- Store Flight Plan 50
- Stormscope lightning data 61, 62, 174
- Strike 61
- Strike mode 62
- SVT 97
- Synthetic Vision Technology 97
- Synthetic Vision Technology (SVT) 168

T

- TA 151
- TAF 64, 75
- TAS 153
- TAWS 94, 95, 96, 149, 150
- Telephone 23, 103, 104, 107, 108, 110, 112
- Terrain 91, 92, 94, 156, 174, 182
- Terrain-SVT 92, 93, 94, 146
- Text message 109, 111, 112
- Text messaging 108
- Timer 2
- TKS FIKI 13
- Topographical data 174, 182
- Traffic 61, 182
- Traffic Advisory 151, 152

- Traffic map page 86, 87, 92, 94, 96
- Transponder 15, 180

U

- Universal Access Transceiver (UAT) 88

V

- Vertical speed guidance 33
- Vertical track 152
- VNAV 168, 169
- VNV 29, 133
- Voice alerts 139
- VRP 42
- Vspeed 2

W

- Waypoint Selection Submenu 43
- Wi-Fi 116, 117
- Wind data 178
- Winds Aloft 76
- WIND Softkey 83

X

- XM Weather Data Link 63

- Flight Instruments
- EIS
- Nav/Com/XPDR/Audio
- AFCS
- GPS Nav
- Flight Planning
- Procedures
- Hazard Avoidance
- Additional Features
- Abnormal Operation
- Annun/Alerts
- Appendix
- Index

- Flight Instruments
- EIS
- Nav/Com/XPDR/Audio
- AFCs
- GPS Nav
- Flight Planning
- Procedures
- Hazard Avoidance
- Additional Features
- Abnormal Operation
- Annun/Alerts
- Appendix
- Index

Blank Page



GARMIN



Garmin International, Inc.

1200 East 151st Street

Olathe, Kansas 66062, U.S.A.

Garmin AT, Inc.

2345 Turner Road SE

Salem, OR 97302, U.S.A.

Garmin (Europe) Ltd.

Liberty House, Hounslow Business Park

Southampton, Hampshire SO40 9LR U.K.

Garmin Corporation

No. 68, Zhangshu 2nd Road

Xizhi District, New Taipei City, Taiwan

Contact Garmin Product Support at

www.flygarmin.com.

For warranty information refer to

www.flygarmin.com